

# HM 170 Open wind tunnel

GUNT offers an "Eiffel" type open wind tunnel as a classic experimental plant in the field of flow around bodies.

The flow medium of air is brought up to the desired velocity by a fan and flows around the model being studied in a meas-

uring section. Additional experiments, such as investigation of the boundary layer or pressure distribution of drag bodies immersed in a flow are available as options.



The new design of the open wind tunnel HM 170



Training at the HM 170 Open wind tunnel at the Technical College for Aeronautical Engineering in Hamburg (Germany)



Measuring lift and drag forces as a function of the angle of attack of an aerofoil with flap and slot

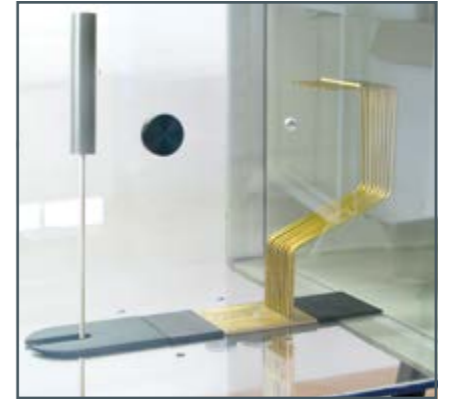

HM 170.28 Measurement of the wake of a cylinder immersed in a flow and demonstration of a wake depression, wake rake consisting of 15 Pitot tubes

HM 170.70 Demonstration of a wind power plant with rotor blade adjustment and variable-speed generator



Measuring lift and drag forces on the streamlined body with the two-component force sensor



Pressure distribution on an aerofoil immersed in a flow

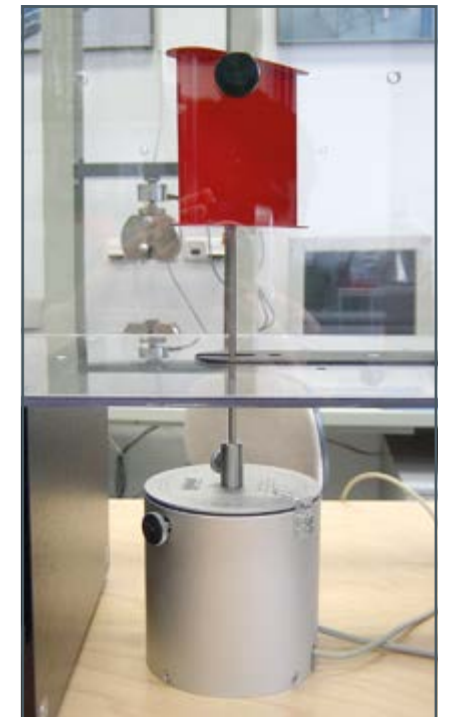

Measuring lift and drag forces and moment on the aerofoil drag body with the three-component force sensor HM 170.40

# HM 170 Selected experiments

## Flow around various drag and lift bodies HM 170.01 – HM 170.14



- determining drag and lift coefficients
- two-component force sensor for measuring drag and lift forces included in HM 170
- visualisation of streamlines by using fog

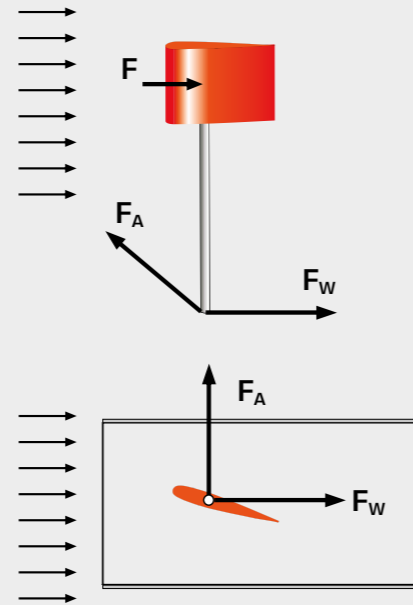

Force measurement on the drag body  
 $F_A$  lift force,  $F_W$  drag

## Demonstration of flutter

### HM 170.20 Airfoil, spring-mounted

- demonstrate flutter (self-excited vibrations)
- natural oscillation behaviour can be influenced by different spring settings

Air flows along an elastic system. Motion-controlled flow forces can cause vibrations with significant amplitudes in the elastic system. This instability phenomenon is called flutter. Flutter is crucial in the design of aircraft, bridges, chimneys and high-voltage power lines. This model is used to demonstrate the aerodynamic excitation of vibrations and instability. By using a stroboscope it is possible to observe the natural oscillation of the wing.

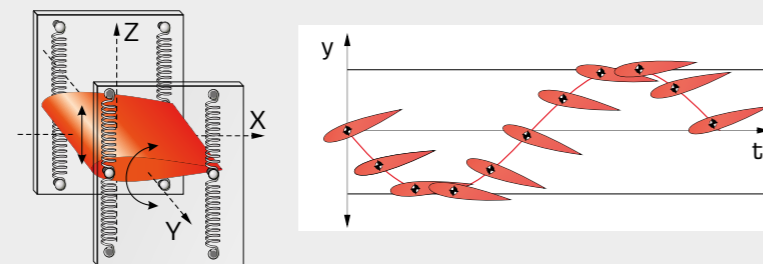
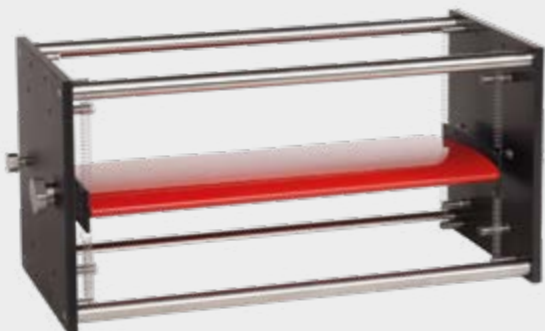

Flutter shown over time

## Pressure distribution at the perimeter of a cylinder immersed in a flow

### HM 170.23 Pressure distribution on a cylinder

- record pressure distribution on the perimeter of the cylinder
- measuring the static pressure
- each pressure measuring point is equipped with a hose connection

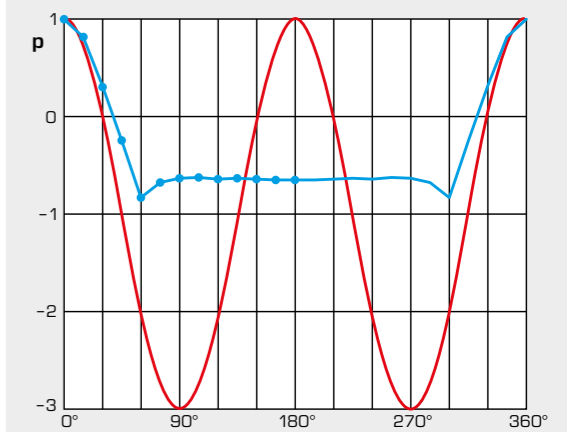
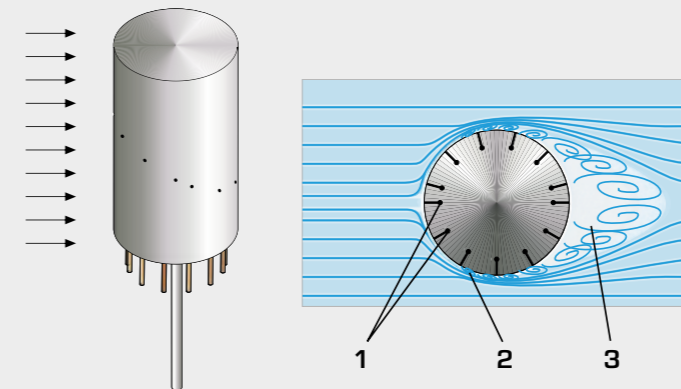

Comparison between measured and ideal pressure distribution when flowing around a cylinder

- ideal pressure distribution (frictionless),
- measured pressure distribution

1 measuring point, 2 flow separation, 3 turbulence

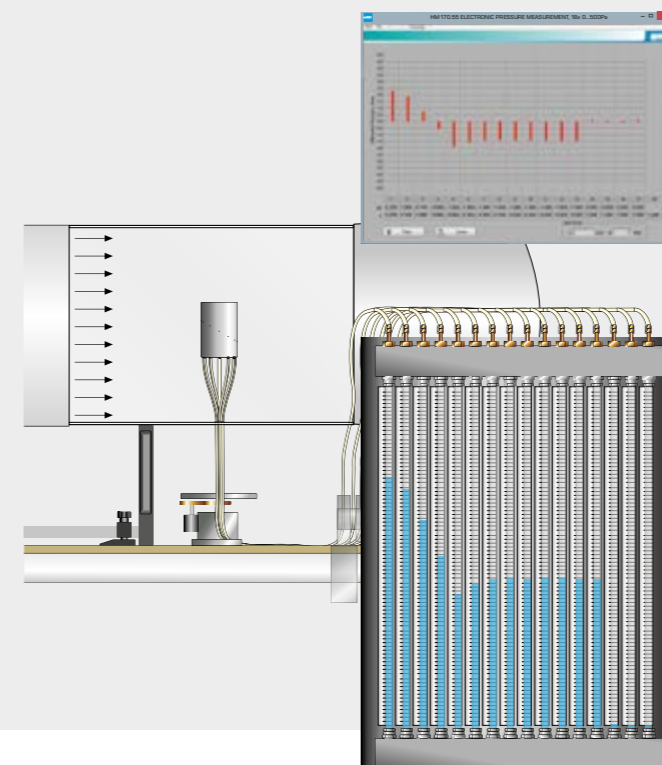

### In conjunction with the electronic pressure measurement HM 170.55:

- recording and display of the pressure distribution on a PC
- saving of measured values

### In conjunction with the HM 170.50 16 tube manometers:

- recording the pressure distribution
- particularly clear display of the pressure distribution by the simultaneous measurement of all pressure measuring points with the tube manometers HM 170.50

## HM 170.70 Wind power plant with rotor blade adjustment

HM170.70, together with the HM170 wind tunnel, allows you to demonstrate a wind turbine with rotor blade pitching and variable-speed generator. The axial fan in the wind tunnel has a variable speed and provides the air flow required for the experiments. The generator is driven directly by a 3-blade rotor. A servo motor is used to change the angle of the rotor blades.

In order to approach different operating points, the nominal speed of the generator can be set via a controller. The rotor speed is precisely measured by Hall sensors built into the generator.



### Features

- wind turbine with variable speed
- rotor blades adjustment angle adjustable via servo motor
- investigation of own rotor blade shapes (3D printing) possible
- network capability: observe, acquire, analyse experiments via customer's own network

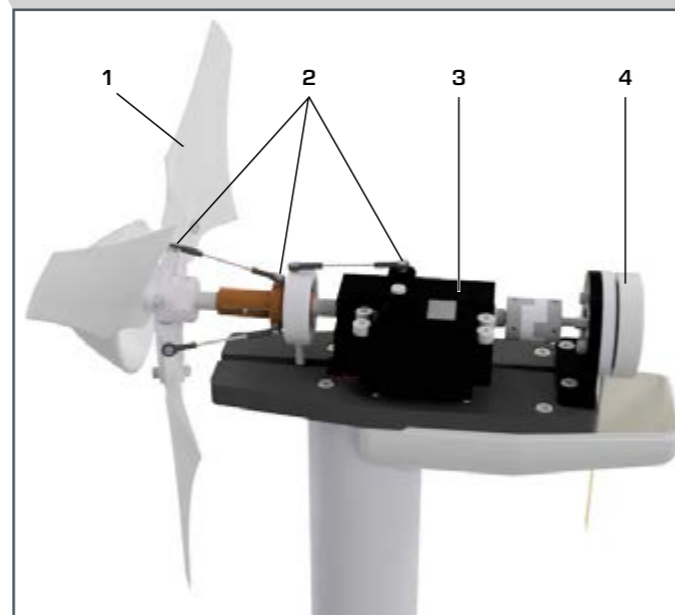

1 rotor blade, 2 rotor blade pitching, 3 servo motor, 4 generator



HM170.70 connected to the open wind tunnel HM170

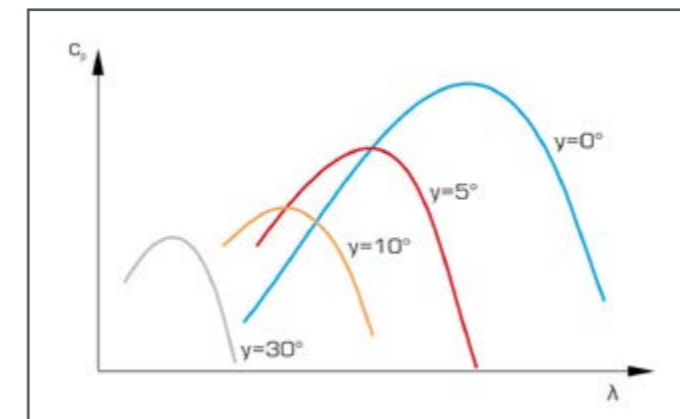











### Determination of the power coefficient tip-speed ratio characteristic diagram

For the investigation of different shapes, rotor blades with straight and with optimised profile are included in the scope of delivery. Using suitable 3D construction and printing methods, new rotor blade shapes developed in-house can also be used.

# HM 170

## Accessories for the wind tunnel

	<b>HM 170.01</b> <b>Drag body sphere</b> diameter: 80 mm		<b>HM 170.07</b> <b>Drag body cylinder</b> height: 100 mm diameter: 50 mm
	<b>HM 170.02</b> <b>Drag body hemisphere</b> diameter: 80 mm		<b>HM 170.08</b> <b>Drag body streamlined shape</b> length: 240 mm diameter: 60 mm
	<b>HM 170.03</b> <b>Drag body circular disc</b> diameter: 80 mm		<b>HM 170.10</b> <b>Drag body paraboloid</b> length: 90 mm diameter: 80 mm
	<b>HM 170.04</b> <b>Drag body circular ring</b> outer diameter: 113 mm inner diameter: 56,5 mm		<b>HM 170.11</b> <b>Drag body concave shape</b> length: 68,65 mm diameter: 80 mm
	<b>HM 170.05</b> <b>Drag body square plate</b> L x W: 71 x 71 mm		<b>HM 170.21</b> <b>Aerofoil with slat and slot flap</b> Aerofoil profile NACA 0015 L x W x H: 100 x 100 x 15 mm
	<b>HM 170.12</b> <b>Lift body square plate</b> L x W: 100 x 100 mm		<b>HM 170.22</b> <b>Pressure distribution on an aerofoil</b> Aerofoil profile NACA 0015 L x W x H: 100 x 60 x 15 mm ■ recording the pressure curve ■ measuring the lift force
	<b>HM 170.09</b> <b>Lift body aerofoil</b> Aerofoil profile NACA 0015 L x W x H: 100 x 100 x 15 mm  additional aerofoil profiles available: <b>HM 170.13</b> NACA 54118 L x W x H: 100 x 100 x 19,65 mm <b>HM 170.14</b> NACA 4415 L x W x H: 100 x 100 x 15,5 mm		<b>HM 170.23</b> <b>Pressure distribution on a cylinder</b> height: 75,5 mm diameter: 50 mm
	<b>HM 170.06</b> <b>Lift body flag</b> L x W: 100 x 100 mm		

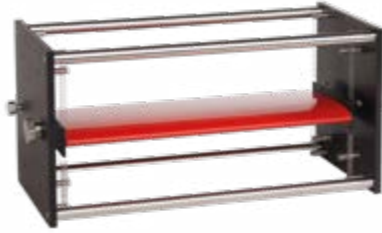
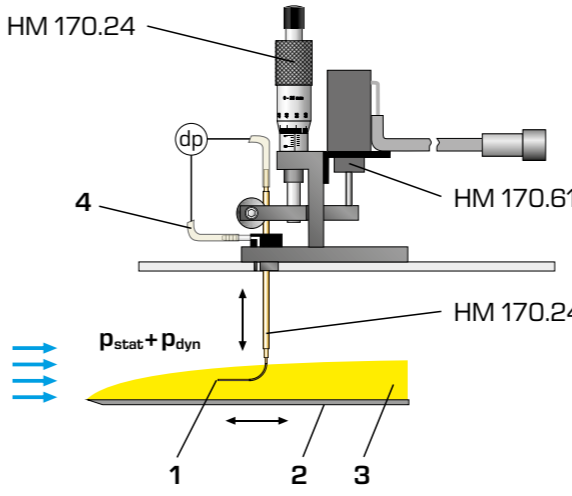
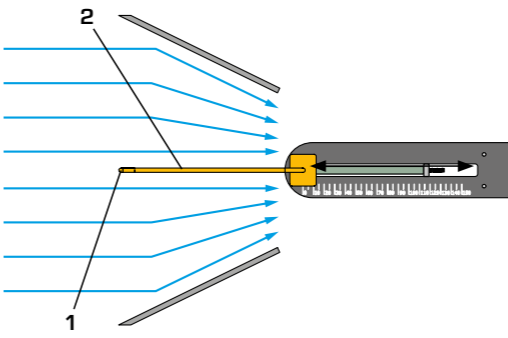
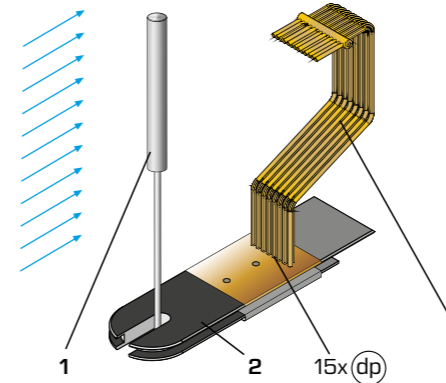
	<b>HM 170.20 Airfoil, spring-mounted</b> Aerofoil profile NACA 0015 L x W x H: 200 x 100 x 15 mm ■ transverse rigidity: 216 N/m ■ torsion rigidity: 0,07..0,28 Nm/rad
	<b>HM 170.24 Boundary layer analysis with Pitot tube</b> Two plates, rough and smooth, L x W x H = 279 x 250 x 3 mm ■ vertically movable Pitot tube measures the pressures at various distances from the plate surface ■ horizontally movable plate for recording pressures along the flow ■ displaying measured values on the PC using HM 170.60 System for data acquisition and HM 170.61 Electronic displacement measurement  Measuring pressures: 1 stagnation point at the Pitot tube (total pressure), 2 flat plate, 3 boundary layer, 4 measuring point for static pressure, dp differential pressure measurement
	<b>HM 170.25 Model "Bernoulli"</b> Air inlet: 292 mm, air outlet: 146 mm, opening angle 52°, Pitotstatic tube, outer diameter: 4 mm ■ horizontally movable Pitotstatic tube ■ wedge-shaped inserts forming a measuring section whose cross-section steadily narrows  Measuring pressures: 1 stagnation point at the Pitotstatic tube (total pressure), 2 Pitotstatic tube
	<b>HM 170.28 Wake measurement</b> Cylinder: D x H: 20 x 100 mm Wake rake consists of 15 Pitot tubes, outer diameter: 2 mm, distance between the Pitot tubes: 3 mm ■ display of measured values on tube manometers HM 170.50 or on the PC using HM 170.55 Electronic pressure measurement  Measuring pressures: 1 cylinder, 2 bracket, 3 wake rake, dp differential pressure measurement

## HM 170 Accessories for the wind tunnel



**HM 170.70 Wind power plant with rotor blade adjustment**  
gearless wind power plant with 3-blade rotor, adjustable rotor blade angle via servo motor, investigation of own rotor blade shapes (3D printing) possible

- replaceable rotor blades with straight and optimised profile
- variable speed generator system
- recording of wind speed, rotor speed and generated electricity

1 connection for wind tunnel HM 170, 2 flow straightener, 3 tower, 4 wind power plant, 5 protective cover

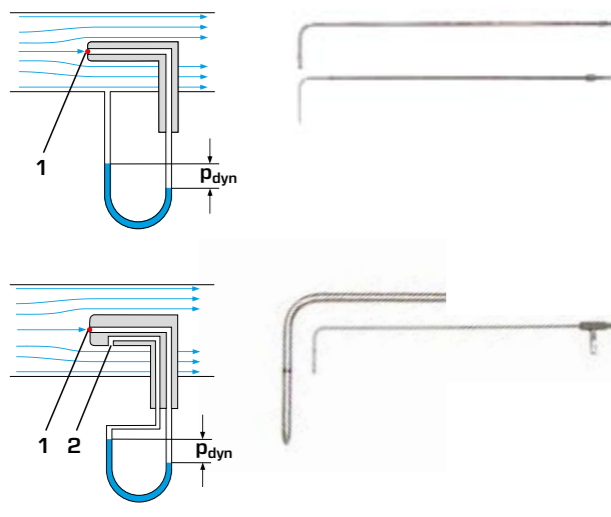

**HM 170.31 Pitot tube**  
outer diameter: 4 mm

**HM 170.32 Pitot tube, small**  
outer diameter: 2 mm

Determining the total pressure:

1 stagnation point  
The pressure in the stagnation point is equal to the total pressure

**HM 170.33 Pitotstatic tube**  
outer diameter: 3 mm

Determining the dynamic pressure:

1 stagnation point, 2 measuring point for static pressure  
The difference between total and static pressure gives the dynamic pressure



**HM 170.53 Differential pressure manometer**

- differential pressure: 0...5 mbar
- graduation: 0,1 mbar



**HM 170.50 16 tube manometers**  
L x W x H: 670 x 220 x 750 mm

- manometer inclination up to max. 1/10
- max. 600 mm WC
- height-adjustable manometer
- individual zero points can be set

The tube manometer operates on the principle of communicating tubes



**HM 170.52 Fog generator**  
L x W x H: 350 x 500 x 300 mm

- power consumption: 500 W



**HM 170.40 Three-component force sensor**  
L x W x H: 370 x 315 x 160 mm (measuring amplifier)  
D x H: 115 x 150 mm (force sensor)

- measuring amplifier with connections for forces and moment
- connection to HM 170.60 possible
- display of drag, lift and moment

Measuring ranges

- drag:  $\pm 4$  N
- lift:  $\pm 4$  N
- moment:  $\pm 0,5$  Nm
- angle:  $\pm 180^\circ$

1 force sensor, 2 measuring amplifier



**HM 170.55 Electronic pressure measurement for HM 170**  
L x W x H: 370 x 315 x 160 mm

- 18 inputs,  $\pm 5$  mbar
- CD with GUNT software included
- data acquisition via USB under Windows

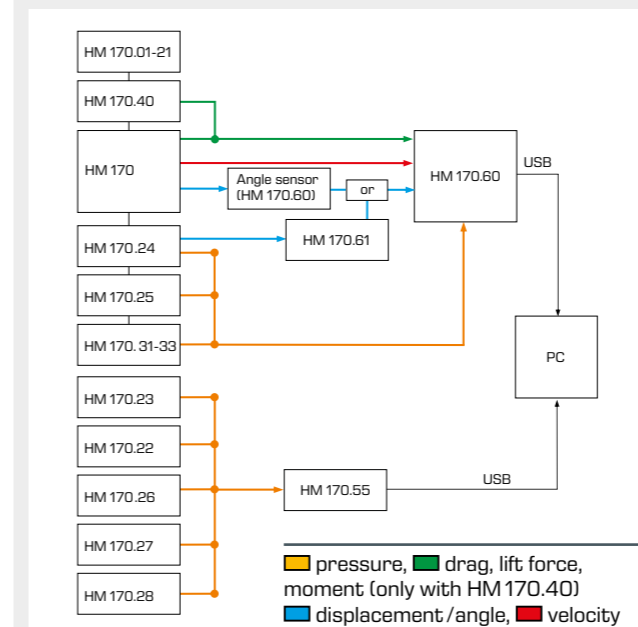

**HM 170.60 System for data acquisition**  
L x W x H: 360 x 330 x 160 mm (interface module)

- CD with GUNT software included
- data acquisition via USB under Windows
- angle sensor

Measuring ranges

- displacement: 0...10 mm
- angle:  $\pm 180^\circ$
- differential pressure:  $\pm 5$  mbar
- velocity: 0...28 m/s
- drag:  $\pm 4$  N
- lift:  $\pm 4$  N
- moment:  $\pm 0,5$  Nm  
(only for HM 170.40 Three-component force sensor)

