

# MT 162

## Hydraulic valves and fittings test stand



The illustration shows MT 162 together with the gate valve from MT 156.

### Learning objectives/experiments

- the following experiments can be conducted together with valves and fittings, such as a wedge gate valve or angle seat valve (MT 156), butterfly valve or non-return valve (MT 157), ball valve or shut-off valve (MT 158)
  - ▶ correct connection of valves to a flange coupling
  - ▶ familiarisation with the terms “nominal pressure” and “test pressure”
  - ▶ performing the final test for the GUNT MT 154, MT 156, MT 157 and MT 158 assembly kits
  - ▶ checking the free movement of the valves and fittings
  - ▶ pressure testing: leak testing of housing and flange seals
  - ▶ pressure testing: leak testing of the valve seat
  - ▶ drafting a test report

### Description

- **mobile test stand for pressure testing of valves and fittings**
- **final testing for the GUNT MT 154, MT 156, MT 157 and MT 158 assembly kits**

MT 162 is used for pressure testing of various types of valves and fittings. The unit can be used to test if the valve opens and closes easily under pressure, and if the housing and seals can withstand the test pressure. A manually operated piston pump draws water from the storage tank, fills the valve interior, and generates the test pressure. A manometer indicates the test pressure. The welded-in collector tray is fitted with a ball valve to allow it to be drained.

The valve under test is attached to a mounting flange and sealed by a blank flange. The piston pump and mounting flange are interconnected via a pressure hose. The test stand includes its own storage tank so it can be operated independently of a water pipe supply. The tank must be topped up occasionally.

The test stand is used in particular for the final testing of the valves assembled and disassembled in the GUNT MT 154, MT 156, MT 157 and MT 158 assembly kits series. This ensures that a successfully completed assembly kit can be examined for operability with a formal test procedure.

# MT 162

## Hydraulic valves and fittings test stand

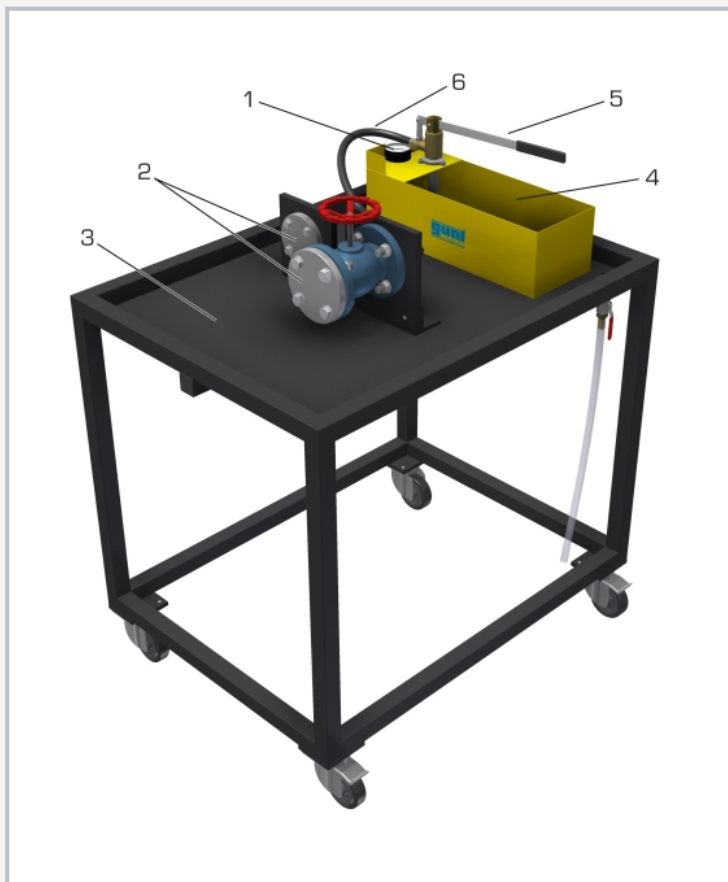

1 manometer, 2 mounting flanges with blank flange, 3 benchtop tray with drain, 4 pressure test pump with water tank, 5 hand lever, 6 hose

A	B
4 bar	5.2 bar
6 bar	7.8 bar
10 bar	13.0 bar
16 bar	20.8 bar
40 bar	52.0 bar

Column A: nominal pressure, column B: test pressure

### Specification

- [1] test stand on which to mount industrial valves and fittings
- [2] pressure testing of valves and fittings
- [3] hand-operated piston pump to generate the test pressure, a return valve to relieve the system pressure, and a manometer for pressure measurement
- [4] 2 different sizes of mounting flange with blank flange and flange seal
- [5] connection of pump and test flange via pressure hose
- [6] test medium: water
- [7] mobile frame with collector tray and ball valve to drain
- [8] water storage tank
- [9] part of the GUNT Practice Line for assembly, maintenance and repair

### Technical data

- Piston pump with tank
- test pressure: 0...60bar
  - tank capacity: 12L
  - manometer: 0...60bar

- Mounting flanges for valves and fittings under test
- DN25
  - DN40

LxWxH: 1000x750x1200mm

Weight: approx. 80kg

### Scope of delivery

- 1 test stand
- 1 set of accessories
- 1 set of tools
- 1 manual

# MT 162

## Hydraulic valves and fittings test stand

### Optional accessories

MT 154	Assembly exercise: shut-off valve
MT 156	Assembly exercise: wedge gate valve and angle seat valve
MT 157	Assembly exercise: butterfly valve and non-return valve
MT 158	Assembly exercise: ball valve and shut-off valve