

HM 421

Propeller type turbine trainer



Learning objectives/experiments

- determination of power output curves at different speeds
 - ▶ hydraulic power output
 - ▶ mechanical power output
- determination of the head
- determination of turbine efficiency
- investigation of the influence of the guide vane position on power output and efficiency

Description

- **characteristics of a propeller type turbine**
- **adjustable guide vanes for setting the power output**
- **network capability: observe, acquire, analyse experiments via customer's own network**

Water turbines are turbomachines which convert water energy into mechanical energy. Mostly, they are used for driving generators for power generation purposes. The propeller type turbine is a reaction turbine with an axial through flow. It has a high specific speed and is suitable for large water flows and small to medium heads. Therefore, the propeller type turbine is used as a "classic" water turbine in run-of-the-river power plants.

The HM 421 helps to investigate the characteristic behaviour of a simple-regulated propeller type turbine during operation. The trainer is provided with a closed water circuit with tank, submersible pump and throttle valve for adjusting the flow rate. The angle of attack of the rotor, and thus the power output of the turbine, are changed by adjusting the guide vanes. The turbine is loaded with a wear-free eddy current brake.

The speed is captured by means of an inductive, non-contact position sensor at the turbine shaft. For determining the turbine power, the eddy current brake is equipped with a force sensor for torque measurement. The pressures at the inlet and outlet of the turbine, the temperature and the flow rate are recorded with sensors. The recorded measured values are displayed digitally and processed further in a PC. The PC is used to calculate the power output data of the examined turbine and to represent them in characteristic curves.

HM 421

Propeller type turbine trainer



1 lever for adjusting the guide vanes, 2 Propeller type turbine, 3 brake, 4 tank with submersible pump, 5 flow rate sensor, 6 handwheel for throttle valve, 7 switch cabinet, 8 level indicator for tank

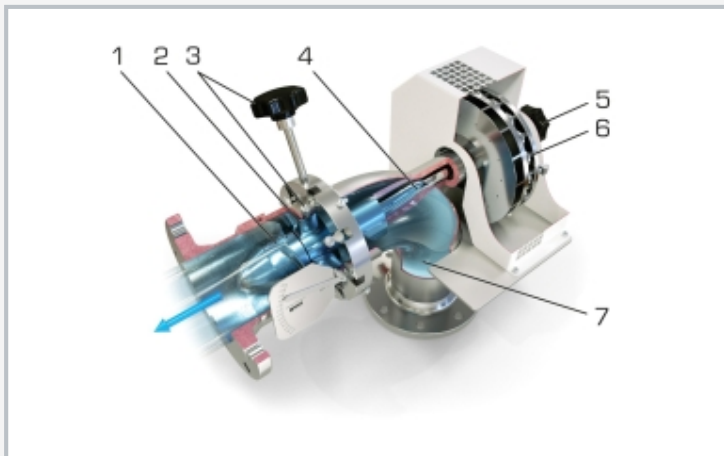

Sectional drawing of a propeller type turbine
1 rotor with fixed blades, 2 adjustable guide vanes, 3 adjustment of guide vanes, 4 turbine shaft, 5 adjustment of the brake, 6 eddy current brake, 7 water inlet

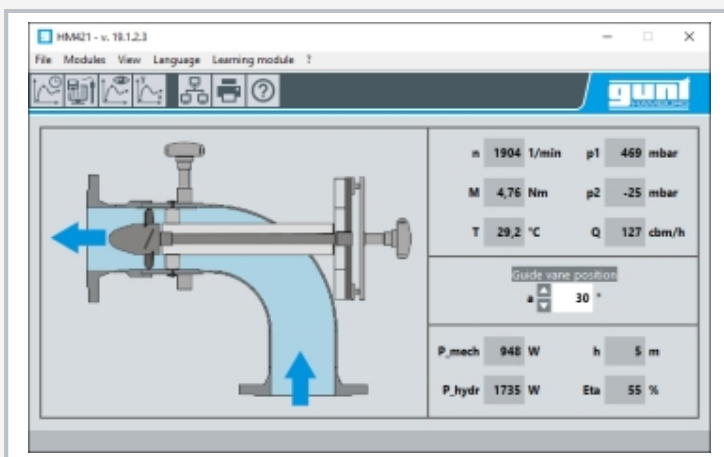

Software screenshot

Specification

- [1] function of a propeller type turbine
- [2] closed water circuit with submersible pump, throttle valve and tank
- [3] adjustment of flow rate with throttle valve
- [4] loading the turbine by use of air-cooled eddy current brake
- [5] rotor with fixed blades
- [6] adjustable guide vanes for setting different angles of attack
- [7] non-contact speed measurement at the turbine shaft and force sensor at the brake for measuring the torque
- [8] digital display for pressures, temperature, flow rate, speed and torque
- [9] network capability: observe, acquire, analyse experiments at any number of workstations with GUNT software via the customer's own LAN/WLAN network
- [10] GUNT software via USB under Windows 10

Technical data

Propeller type turbine

- max. output: 1000W
- max. speed: 3700min⁻¹
- distributor

8 guide vanes, adjustable: -15°...45°
external Ø: 120mm, internal Ø: 60mm

Rotor, 4 blades, fixed
external Ø: 120mm, internal Ø: 60mm, pitch: 80mm

Submersible pump with motor

- max. flow rate: 250m³/h
- max. pump head: 11m
- nominal power: 3,1kW

Tank: approx. 350L

Measuring ranges

- temperature: 0...100°C
- pressure [at turbine inlet]: 0...1 bar rel.
- pressure [at turbine outlet]: -1...0,6bar rel.
- flow rate: 13...200m³/h
- torque: 0...10Nm
- speed: 0...6500min⁻¹

400V, 50Hz, 3 phases
LxWxH: 1450x1250x1650mm
Weight: approx. 430kg

Required for operation

PC with Windows recommended

Scope of delivery

- 1 trainer
- 1 GUNT software + USB cable
- 1 set of instructional material

HM 421

Propeller type turbine trainer

Optional accessories

for Remote Learning

GU 100 Web Access Box

with

HM 421W Web Access Software