

CE 586

Precipitation and flocculation



2E

The illustration shows: supply unit (left) and trainer (right).

Description

- **removal of dissolved substances (e.g. iron) by precipitation and flocculation**
- **sedimentation of the flocs in the lamella separator**

CE 586 demonstrates the removal of dissolved substances by precipitation and flocculation with subsequent sedimentation.

First, raw water is produced in a tank to contain dissolved metal (e.g. iron). A pump transports the raw water to the precipitation tank. Here the precipitant is added (e.g. caustic soda). Due to the reaction of the dissolved metal ions with the precipitant, insoluble metal hydroxides form (solids). From here the water flows into a flocculation tank divided into three chambers. The purpose of flocculation is to improve the sedimentation properties of the solids. By adding a coagulant in the first chamber the repulsive forces between the solid particles are cancelled out.

The solid particles aggregate into flocs (coagulation). To generate larger flocs, a flocculant is then added (flocculation). In the third chamber low flow velocities are present to prevent any turbulence. Turbulence would impede the formation of flocs. The now well sedimentable flocs are then separated from the treated water in a lamella separator. The treated water and the sedimented flocs (sludge) are collected in two tanks.

Flow rate, temperature and the pH value are measured. In addition, the pH value in the precipitation tank can be controlled. For measuring the conductivity an external meter is available. Samples can be taken at all relevant points.

Analysis technology is required to analyse the experiments. The choice of analysis technology depends on the substances used. Trivalent metallic salts are usually well suited as coagulants. Common flocculants are organic polymers.

Learning objectives/experiments

- familiarisation with precipitation and flocculation
- effect of the pH value on precipitation
- creation of a stable operating state
- determination of the required metering quantities (precipitant, coagulant, flocculant)
- functional principle of a lamella separator

CE 586

Precipitation and flocculation

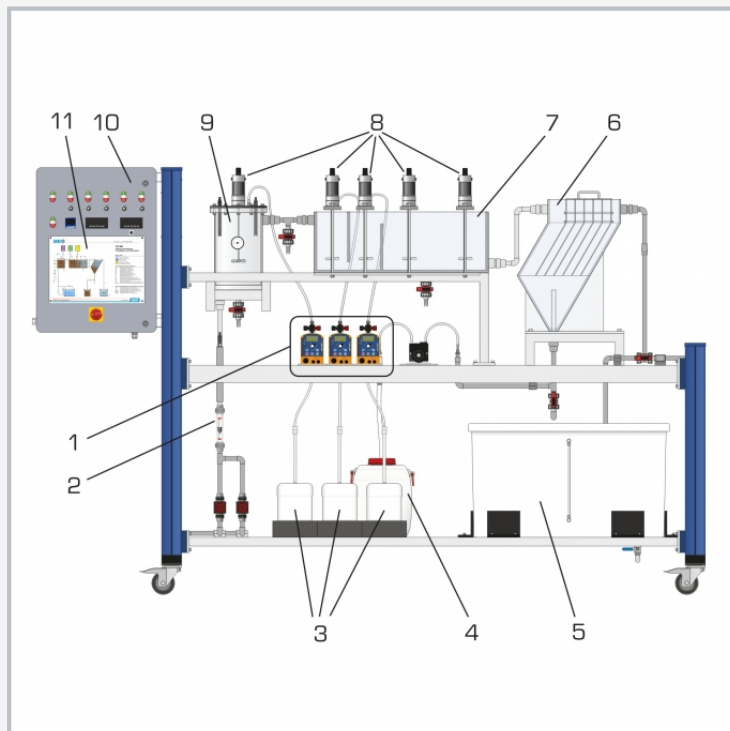

1 metering pumps, 2 flow meter, 3 chemicals tank, 4 sludge tank, 5 treated water tank, 6 lamella separator, 7 flocculation tank, 8 stirring machines, 9 precipitation tank, 10 switch cabinet, 11 process schematic

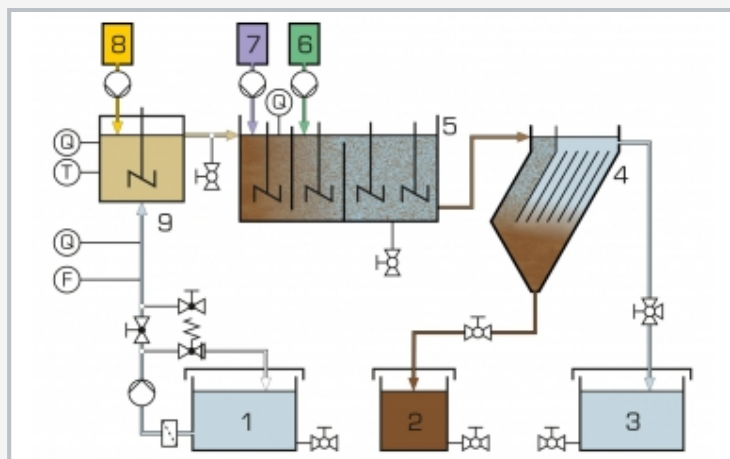

1 raw water, 2 sludge, 3 treated water, 4 lamella separator, 5 flocculation tank, 6 flocculant, 7 coagulant, 8 precipitant, 9 precipitation tank; F flow rate, Q pH value, T temperature

Specification

- [1] precipitation and flocculation of dissolved substances (e.g. iron)
- [2] separate supply unit with tank and pump for raw water
- [3] precipitation tank with stirring machine
- [4] flocculation tank with 3 chambers and 4 stirring machines
- [5] 3 metering pumps for chemicals
- [6] sedimentation of the flocs in the lamella separator
- [7] measurement of flow rate, temperature and pH value
- [8] control of the pH value in the precipitation tank
- [9] conductivity meter

Technical data

Tanks

- raw water and treated water: each 300L
- precipitation tank: 10L
- flocculation tank: 45L
- sludge tank: 15L

Lamella separator

- number of lamellas: 6
- angle of inclination of lamellas: 60°

Raw water pump

- max. flow rate: 180L/h
- max. head: 10m

Metering pumps

- max. flow rate: each 2,1L/h
- max. head: each 160m

Stirring machines

- max speed: each 600min⁻¹

Measuring ranges

- flow rate: 15...160L/h
- pH value: 0...14
- temperature: 0...60°C
- conductivity: 0...2000µS/cm

230V, 50Hz, 1 phase

230V, 60Hz, 1 phase; 120V, 60Hz, 1 phase

UL/CSA optional

LxWxH: 1550x790x1150mm (supply unit)

LxWxH: 3100x790x1950mm (trainer)

Total weight: approx. 435kg

Required for operation

water connection, drain, iron(III) chloride, iron(III) sulfate, flocculant, caustic soda, hydrochloric acid

Scope of delivery

- 1 trainer
- 1 supply unit
- 1 conductivity meter
- 1 calibration solution (0,5L potassium chloride)
- 1 set of hoses
- 1 set of instructional material