

CE 380

Fixed bed catalysis



Description

- chemical fixed bed catalysis
- three reactors for comparative experiments
- product analysis with photometer

Catalysts enable or accelerate chemical reactions. CE 380 is designed for the decomposition reaction of dissolved saccharose in glucose and fructose.

A peristaltic pump transports the reactant (saccharose solution) into bottom of the reactor from a tank. The catalyst takes the form of a fixed bed in the reactor. The saccharose solution flows through the fixed bed. In the process, saccharose is decomposed into glucose and fructose. The catalyst accelerates the reaction and so increases the yield of the product (glucose/fructose mixture). The product is collected in a tank.

Three reactors allow various catalyses to be compared. The chemical catalyst used is exchanger resin. A regulated heating water circuit additionally permits analysis of the influence of temperature on the reaction.

To determine the glucose concentration in the product, a photometer specifically adapted to the unit is supplied. The photometer data are transferred to a PC and evaluated by software. The flow injection analysis (FIA) CE 380.01 is available as an optional accessory. The FIA enables a larger number of measurements to be performed during the experiment compared to manual analysis, while at the same time reducing the effort involved and improving reproducibility.

Learning objectives/experiments

- fundamentals of chemical catalysis
- dependence of the reaction on
 - ▶ catalyst mass
 - ▶ temperature
- use of a photometric analyser
- drawing up a quantity balance
- determining yield

CE 380

Fixed bed catalysis

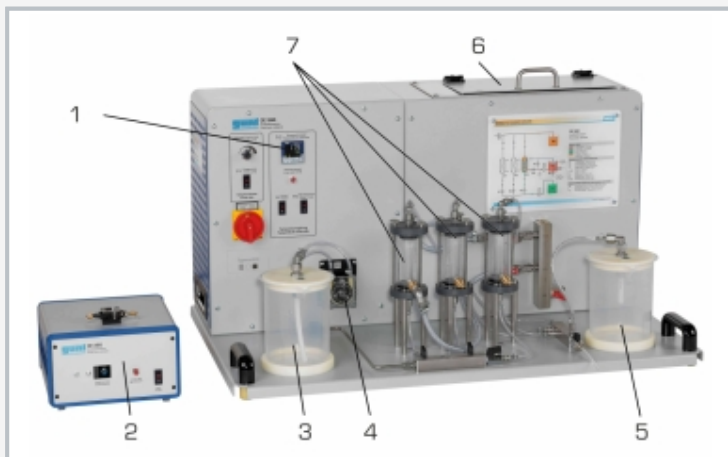

1 temperature controller, 2 photometer, 3 reactant tank, 4 feed pump, 5 product tank, 6 water tank for heating circuit, 7 reactor

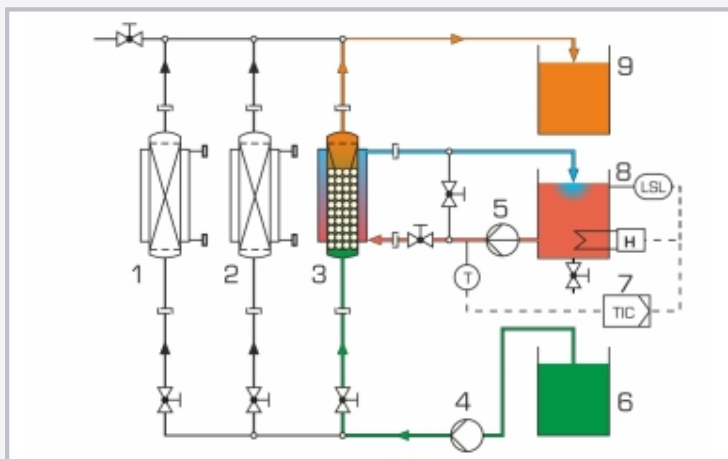

1-3 reactor, 4 feed pump, 5 heating circuit pump, 6 reactant tank, 7 temperature controller, 8 water tank with heater and level switch, 9 product tank



Photometer: 1 cuvette holder, 2 light source connection, 3 spectrometer connection

Specification

- [1] investigation of a catalytic reaction
- [2] 3 reactors (PMMA) for comparison of various fixed bed catalyses
- [3] peristaltic pump with adjustable speed to transport the reactant into the reactors
- [4] regulated heating circuit with water tank, heater and pump to regulate the reactor temperatures
- [5] 1 scaled container for reactant and product respectively
- [6] photometer for analysis of the product
- [7] GUNT software for data acquisition via USB under Windows 11 (photometer)
- [8] flow injection analysis (CE 380.01) available as accessory

Technical data

Reactors

- diameter: approx. 10mm
- height: approx. 120mm

Peristaltic pump

- max. flow rate: approx. 50mL/min

Heating circuit pump

- max. flow rate: 10L/min
- max. head: 30m
- power consumption: 120W

Heating circuit

- tank: approx. 7500mL
- heater: approx. 1kW

Tanks for reactant and product

- capacity: approx. 2000mL
- scale division: 50mL
- material: PP

Photometer wavelength: 610nm

230V, 50Hz, 1 phase

230V, 60Hz, 1 phase

120V, 60Hz, 1 phase

UL/CSA optional

LxWxH: 1000x680x500mm (experimental unit)

LxWxH: 260x260x180mm (photometer)

Weight: approx. 63kg

Required for operation

PC with Windows

Scope of delivery

- 1 experimental unit
- 1 photometer
- 1 packing unit of chemical catalyst
- 1 software for photometer
- 1 set of accessories
- 1 set of instructional material

CE 380

Fixed bed catalysis

Optional accessories

WP 300.09

Laboratory trolley

CE 380.01

Flow injection analysis