

ET 351C

Thermodynamics of the refrigeration circuit



Description

- **compression refrigeration system for thermodynamic investigations**
- **indirectly heated evaporator and water-cooled condenser**
- **open compressor with pendulum bearing drive motor for torque measurement**

In this trainer, great care was taken to make the thermodynamic processes in the refrigeration system as transparent as possible. The capacities of compressor, evaporator and condenser can be measured. Pressure and temperature measuring points are located at all the relevant locations to also allow for the pressure and heat losses in a refrigeration system to be investigated in detail.

The refrigeration circuit of ET 351C contains an open compressor with variable speed, a water-cooled condenser, a thermostatic expansion valve and an evaporator heated by a hot water circuit.

The compressor is driven via a pendulum bearing motor with frequency converter for speed adjustment. A force transducer permits the measuring of the drive torque. Using the speed the mechanical drive power of the compressor can thus be determined. The electrical heating power of the hot water circuit can be freely adjusted and is displayed. The condenser capacity is measured via the cooling water flow.

The measured values can be read on digital displays. At the same time, the measured values can also be transmitted directly to a PC via USB. The data acquisition software is included. The software allows for the process to be represented in the log p-h diagram and displays the key characteristic variables of the process, e.g. compressor pressure ratio and coefficient of performance.

Learning objectives/experiments

- cyclic process in the log p-h diagram
- comparison of the real cyclic process and the ideal cyclic process
- balances at the evaporator and condenser
- calculation of the motor power via speed and torque
- determination of losses
- calculation of the coefficient of performance
- operating behaviour under load
- non-steady-state operating behaviour

ET 351C

Thermodynamics of the refrigeration circuit



1 expansion valve, 2 evaporator, 3 refrigerant flow meter, 4 pressure switch, 5 process schematic, 6 receiver, 7 hot water circuit of the evaporator, 8 drive motor, 9 compressor, 10 cooling water flow meter, 11 condenser, 12 displays and controls

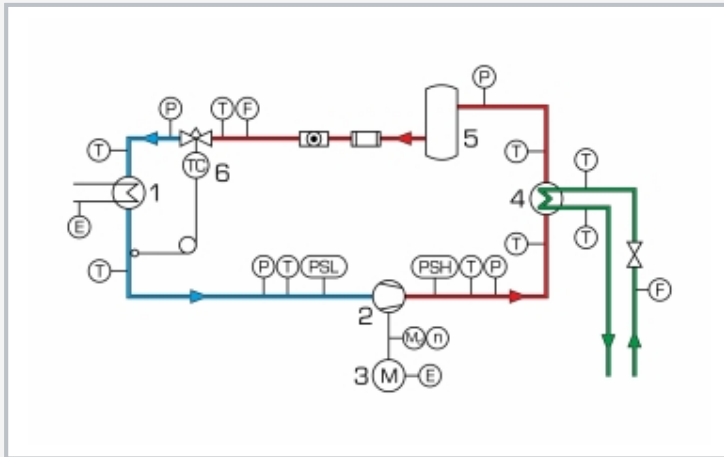

1 evaporator, 2 compressor, 3 drive motor, 4 condenser, 5 receiver, 6 expansion valve; P pressure, T temperature, F flow rate, M_d torque, n speed, E electrical power; PSL, PSH pressure switch; blue: low pressure, red: high pressure, green: cooling water

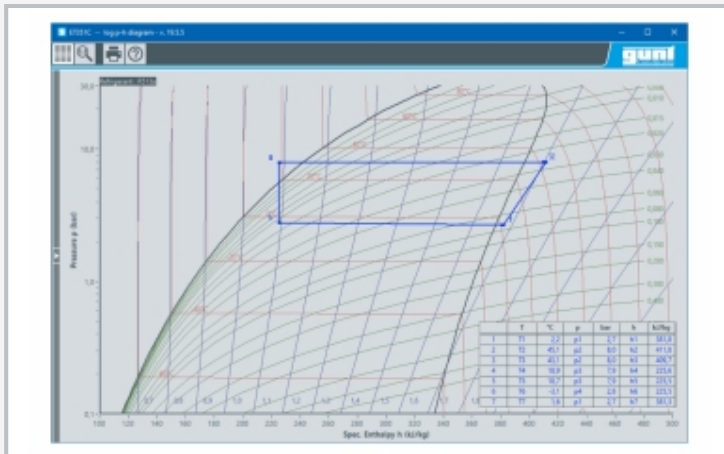

Software screenshot: log p-h diagram

Specification

- [1] thermodynamic investigation of a refrigeration circuit
- [2] refrigeration circuit with open compressor, water-cooled condenser, thermostatic expansion valve and indirectly heated evaporator
- [3] compressor drive with speed-controlled motor via V-belt
- [4] motor on pendulum bearing for torque measurement
- [5] tube evaporator with hot water circuit as cooling load
- [6] water-cooled coaxial coil heat exchanger as condenser
- [7] displays for temperature, pressure, flow rate, speed, torque and power at the equipment
- [8] GUNT software for data acquisition via USB under Windows 10
- [9] refrigerant R513A, GWP: 631

Technical data

Open compressor

- refrigeration capacity: approx. 965W (at a speed of 1450min⁻¹ and 5/40°C)

Heater: 1x 1000W

Condenser, capacity: 1300W

Refrigerant

- R513A, GWP: 631, filling volume: 2kg, CO₂-equivalent: 1,3t

Measuring ranges

- temperature: 9x -30...100°C, 1x 0...100°C
- pressure: 1x -1...9bar, 1x -1...24bar, 4x -1...15bar
- torque: [compressor] 0...10Nm
- speed: [compressor] 0...2500min⁻¹
- power consumption: [compressor] 0...1125W
- power: [heater] 0...1125W
- flow rate: [water] 5...70g/s
- flow rate: [refrigerant] 0...0,5L/min

230V, 50Hz, 1 phase

230V, 60Hz, 1 phase; 230V, 60Hz, 3 phases

UL/CSA optional

LxWxH: 1520x790x1760mm

Weight: approx. 120kg

Required for operation

water connection, drain

PC with Windows recommended

Scope of delivery

- 1 trainer
- 1 set of hoses, 1 manual pump
- 1 GUNT software + USB cable
- 1 set of instructional material

ET 351C

Thermodynamics of the refrigeration circuit

Optional accessories

for Remote Learning

010.10000

GU 100

Web Access Box

with

061.351C0W

ET 351CW

Web Access Software