

IA 500

Automated process with cobot



Description

- automation of a process with a quality collaborative industrial robot
- experimental plant controlled with PLC, can be operated via touch screen
- hydraulically generated test force and clamping forces

The main task of the IA 500 experimental plant is to convert a manual process – in this case a classic tensile test – into a fully automated process. The goal is a fully automated tensile test without human intervention. Automation is developed step by step and underpinned with practical tasks, instructions and information.

The tasks include a process analysis in which the automation potential is worked out first with specific work steps. The solutions developed are then implemented, tested and optimised. The experimental plant is delivered in a fully automated state. All files required to set the system to factory settings are included.

A collaborative robot (cobot) with a gripper is used to pick and insert the tensile specimen and dispose of the fragments. Other components of the experimental plant include a magazine for the tensile

specimens that monitors the fill level; a stepper motor with a worm gear screw jack; and a hydraulic system. The tensile test is controlled by a stepper motor controller.

All necessary measured values are recorded and stored during the tensile test. The simultaneous transfer of the measured values to a PLC enables easy analysis and the representation of the process in real time. Via a USB interface the measured values can be transferred to a PC and stored there (e.g. via MS Excel).

All work steps are controlled by the PLC and checked and monitored using previously defined parameters. The device is operated via a touch screen. The user interface can also be displayed on additional end devices (screen mirroring).

In the GUNT Media Center, extensive technical information is available as didactic multimedia teaching materials, such as information on the installed components and software packages. The teaching material is supplemented by worksheets with solutions.

Learning objectives/experiments

- familiarisation with and development of process automation
- analyse a process
- identify automation potential
- generate solutions using creativity techniques (e.g. 635 Method, mind mapping, morphological box)
- compare and evaluate solutions, e.g. using “weighted point evaluation”
- establish a communication topology: human-machine, machine-IT, machine-energy supply
- design hydraulic systems
- teach the cobot
- cobot programming, fault finding, program optimisation

Use of digital technologies to develop digital skills

- retrieve information from digital networks
- use digital learning media and digital technologies
- MS Excel for analysing data

IA 500

Automated process with cobot

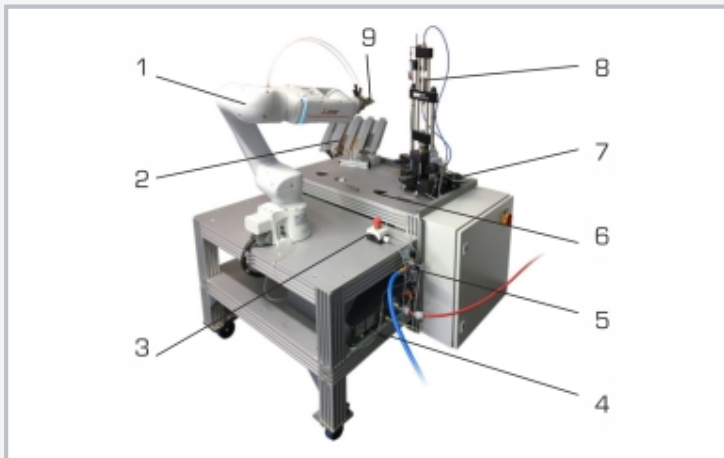

1 industrial collaborative robot (cobot), 2 specimen store with space for 4 materials, 3 emergency stop switch, 4 robot controller, 5 pneumatics, 6 openings for disposal of the fragments, 7 stepper motor drive, 8 materials tester, 9 gripper

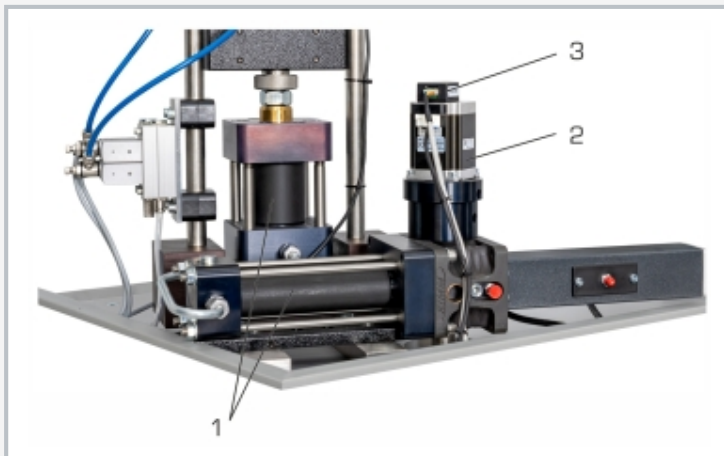

Servo drive: 1 hydraulic cylinders, 2 stepper motor, 3 encoder



Jog modes
 XYZ: coordinate system of robot
 Tool: coordinate system of gripper
 Work: user-defined coordinate system

Specification

- [1] automation of a manual process
- [2] develop the automation potential in a process analysis as well as implementation, testing and optimisation of the developed solutions
- [3] part of the GUNT DigiSkills programme
- [4] high-quality industrial collaborative robot (cobot) with associated controller and gripper
- [5] collet chucks with electropneumatic centring to hold the tensile specimen
- [6] application of force via stepper motor with a screw jack and hydraulics, controlled via stepper motor controller
- [7] emergency stop equipment
- [8] fill level monitoring in the specimen store via inductive proximity switches
- [9] force measurement via pressure sensor
- [10] path measurement via linear potentiometer
- [11] experimental plant controlled with PLC, can be operated via touch screen
- [12] data transfer via USB for versatile external use of measured values and screenshots
- [13] network capability: access to ongoing experiments and their results from up to 10 external workstations simultaneously via the local network
- [14] screen mirroring: possible to mirror the user interface on up to 10 end devices
- [15] multimedia instructional materials online in GUNT Media Center

Technical data

PLC: Siemens S7-1200

Industrial collaborative robot, cobot

- model: Mitsubishi RV-5AS-D
- range: 910mm
- load capacity: 5kg
- pneumatics: double valve set
- gripper force: 250N (6bar)
- gripper travel: 6mm

Stepper motor

- holding torque: 2,3Nm
- resolution: 1,8°/step
- encoder: 16384 pulse/revolution

Worm gear screw jack

- max. compressive/tensile force: 10kN
- stroke/drive shaft revolution: 0,25mm

Measuring ranges

- pressure: 0...100bar
- travel: 0...50mm

230V, 50Hz, 1 phase

LxWxH: 1200x1250x1750mm

Weight: approx. 250kg

Scope of delivery

experimental plant, control element (HMI), set of specimens, online access to the GUNT Media Center

IA 500

Automated process with cobot

Optional accessories

IA 501

Programming a servo drive

WP 300

Materials testing, 20kN