

# ET 101

## Simple compression refrigeration circuit



2E

### Description

- introduction to refrigeration
- model of a compression refrigeration system / heat pump
- cooling and heating of the heat exchangers directly tangible

The purpose of a refrigeration system is the cooling of materials and products, e.g. to protect food from spoiling. Cooling can be described as a process in which heat is removed from the environment.

A commonly used refrigeration system is the so-called compression refrigeration system. In this system refrigerant flows through four main elements: compressor, condenser, expansion element and evaporator. The refrigeration system uses the fact that the refrigerant has a low boiling point at low pressure. This means that evaporation takes place on the low pressure side. During the evaporation of the refrigerant heat is removed from the environment and it is cooled. The condensation takes place on the high pressure side after the evaporator. Here the heat is discharged into the environment. If not the cooling effect but the discharged heat is used, this is called a heat pump.

The setup of ET 101 represents a simple compression refrigeration system. Evaporator and condenser have been designed as a pipe coil with each end immersed in a water-filled tank. The water simulates the environment. A thermostatic expansion valve serves as expansion element. Two manometers indicate the two system pressures on the high and low pressure sides. On an additional scale on the manometer the evaporation temperature of the refrigerant is indicated. Two thermometers measure the temperature of the water in the tanks.

This allows for calculations of the amount of heat removed from the environment (evaporator, cold water) and added to the environment (condenser, hot water). A sight glass indicates the aggregate state of the refrigerant upstream of the expansion valve.

### Learning objectives/experiments

- fundamentals of a compression refrigeration circuit
- key components of a refrigeration system
  - ▶ compressor, evaporator, condenser, expansion element
- relationship between the pressure and boiling point of a liquid
- operation of a refrigeration system / heat pump
- developing a basic understanding of the thermodynamic cycle
- simple energy balance

# ET 101

## Simple compression refrigeration circuit

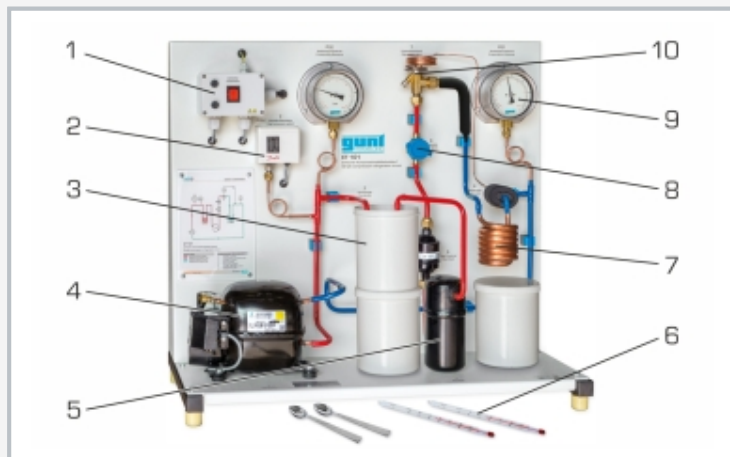

1 main switch, 2 pressure switch, 3 condenser with water tank, 4 compressor, 5 receiver, 6 thermometer, 7 evaporator, 8 sight glass (refrigerant), 9 manometer, 10 expansion valve

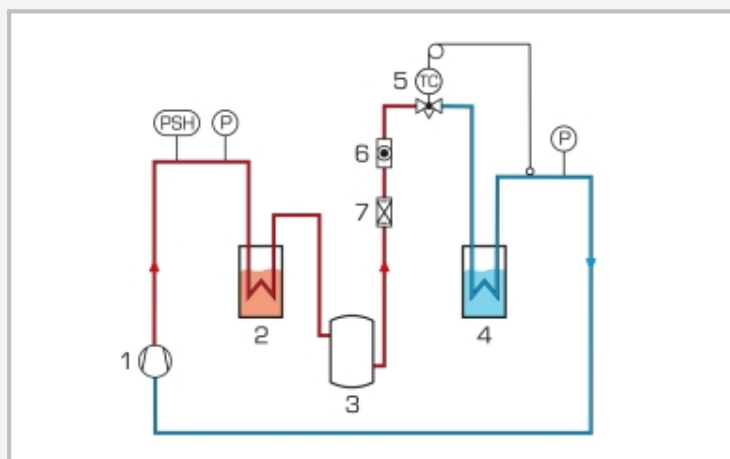

Process schematic of the refrigeration circuit: 1 compressor, 2 condenser, 3 receiver, 4 evaporator, 5 expansion valve, 6 sight glass, 7 filter/drier; PSH pressure switch, P pressure

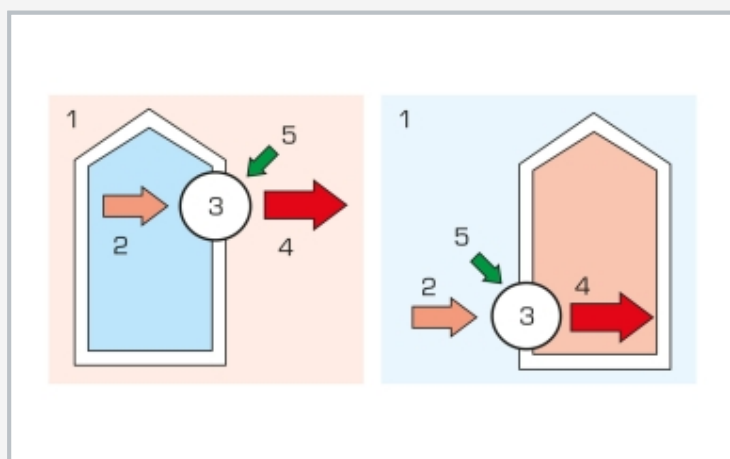

Cooling (left) and heating (right) using a heat pump  
1 environment, 2 absorbed heat, 3 heat pump, 4 discharged heat, 5 electric energy

### Specification

- [1] fundamentals of refrigeration in a simplified model
- [2] typical compression refrigeration system with piston compressor, thermostatic expansion valve, evaporator and condenser (each in the shape of a pipe coil)
- [3] 2 manometers with temperature scale for the refrigerant show the values of the refrigerant on the high and low pressure sides
- [4] 2 water-filled tanks with thermometer to demonstrate the cooling and heating effect
- [5] pressure switch to protect the compressor
- [6] sight glass to monitor the aggregate state of the refrigerant
- [7] refrigerant R513A, GWP: 631

### Technical data

#### Compressor

- power consumption: 104W at 5/40°C
- refrigeration capacity: 278W at 5/40°C
- displaced volume: 2,72cm<sup>3</sup>

Tank: 4x 1700mL

#### Refrigerant

- R513A
- GWP: 631
- filling volume: 450g
- CO<sub>2</sub>-equivalent: 0,3t

#### Measuring ranges

- pressure: -1...12,5bar, -1...25bar
- temperature: -50...40°C, -40...80°C, 2x -10...50°C

230V, 50Hz, 1 phase  
230V, 60Hz, 1 phase  
120V, 60Hz, 1 phase  
UL/CSA optional  
LxWxH: 750x360x690mm  
Weight: approx. 30kg

### Scope of delivery

- 1 experimental unit
- 4 water tanks
- 2 thermometers
- 2 spoons
- 1 set of instructional material

# ET 101

## Simple compression refrigeration circuit

Optional accessories

WP 300.09

Laboratory trolley