

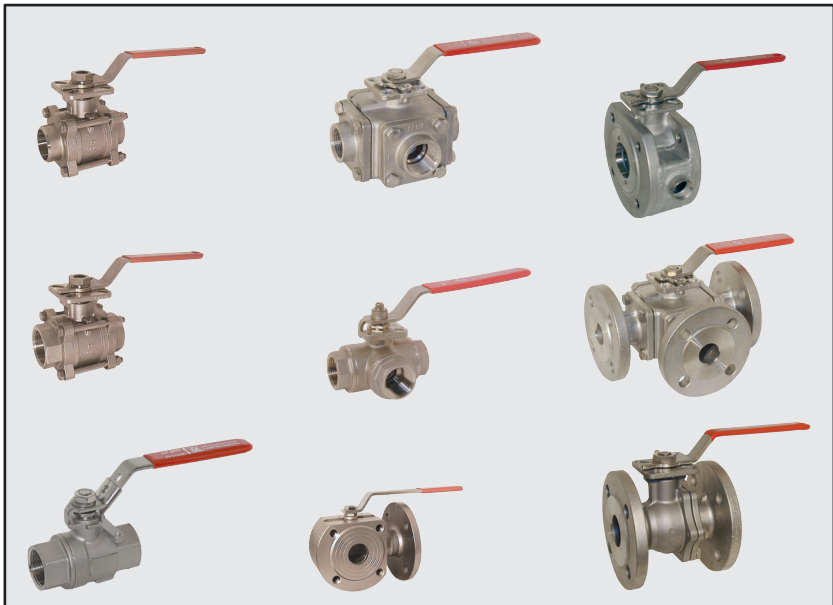

*Qualität von Anfang an.*

# Operation and Installation Manual Ball Valves



© by **END-Armaturen GmbH & Co. KG**

All rights reserved. END-Armaturen GmbH & Co. KG claims copyright over this documentation.

This documentation may neither be altered, expanded, reproduced nor passed to third parties without the written agreement of END-Armaturen GmbH & Co. KG. This restriction also applies to the corresponding drawings.

END-Armaturen GmbH & Co. KG has the right to change parts of the valves and armatures at any time without prior or direct notice to the client. The contents of this publication are subject to change without notice.

This publication has been written with great care. However, END-Armaturen GmbH & Co. KG cannot be held responsible, either for any errors occurring in this publication or for their consequences.

The products are specified by the statements in this documentation; no assurance or the properties is given.

**END-Armaturen GmbH & Co. KG**

Oberbecksener Straße 78  
D-32547 Bad Oeynhausen  
Telefon: 05731 / 7900 - 0  
Telefax: 05731 / 7900 - 199  
Internet: <http://www.end.de>  
E-Mail: [post@end.de](mailto:post@end.de)

Edition: 07/2016

## Inhalt

<b>1</b>	<b>Foreword</b>	<b>4</b>
<b>2</b>	<b>General advice</b>	<b>5</b>
2.1	Validity	5
2.2	Inward monitoring	5
2.3	Complaints	5
2.4	Warranty	5
2.5	Symbols and their signification	6
<b>3</b>	<b>Safety advice</b>	<b>7</b>
3.1	Personal advice	7
3.1.1	Safety advices for mounting	7
3.1.2	Safety advice for adjustment / starting	7
3.1.3	Safety advice for maintaining / repairing	8
3.2	Device safety	9
<b>4</b>	<b>Name-plate</b>	<b>10</b>
<b>5</b>	<b>Ball valves</b>	<b>11</b>
5.1	General	11
5.2	Corresponding use	11
5.3	Operation	11
5.4	Mounting / Disassembly	11
5.4.1	Mounting with threaded connection	12
5.4.2	Mounting with welded connection	13
5.4.2.1	Disassembly of the center part of the ball valve	13
5.4.2.2	Welding of the connection ends	14
5.4.2.3	Mounting of the center part	15
5.4.3	Mounting with flanged connection	16
5.5	Maintenance	17
5.5.1	Readjusting of the gland	18
5.5.2	Exchange of the ball and the sealing	19
5.5.2.1	3-part ball valve with threaded or welded connection	19
5.5.2.2	Multiple part ball valve with flanged connection	22

## 1 Foreword

Dear customer,  
Dear assembler / user,

these operation and installation manuals are intended to give you the knowledge, which is necessary for you to be able to carry out the mounting and adjustment of the ball valves rapidly and correctly.



Please read these instructions carefully and pay particular attention to the advice and warning notes.

Only instructed and qualified mechanician should mount, adjust or maintain the ball valves.

If you have any questions in relation to the ball valves we shall be pleased to answer them. The telephone number will be found on the inside cover of these operation and installation manual.

Yours  
**END-Armaturen GmbH & Co. KG**

## 2 General advice

### 2.1 Validity

These mounting and installation manual is valid for the standard version of the ball valves.

### 2.2 Inward monitoring

Please check

- directly after delivery the ball valves for any transport damages and deficiencies.
- with reference to the accompanying delivery note the number of parts.

Do not leave any parts in the package.

### 2.3 Complaints

Claims for replacement or goods which relate to transport damage can only be considered valid if the delivery company is notified without delay.

In case of returns (because of transport damage / repairs), please make a damage protocol and send the parts back to the manufacturer, if possible in the original packaging.

In case of a return, please mention the following:

- Name and address of the consignee
- Stock-/ ordering-/ article-number
- Description of the defect

### 2.4 Warranty

For our ball valves we give a guarantee period in accordance with the sales contract. The end of the normal duration of life of the wearing parts represents no defect.

The warranty and guarantee rules of **END-Armaturen GmbH & Co. KG** are applicable.

### 2.5 Symbols and their signification



Paragraphs which are identified with this symbol contain very important advices; this also includes advices for averting health risks. Observe these paragraphs without fail!



Paragraphs which are identified with this symbol contain very important advices, this also includes how to avoid damage to property. Observe these paragraphs without fail!



This symbol indicates paragraphs which contain comments / advices or tips.



This spanner identifies the description of actions which you should carry out.

## 3 Safety advice

Depending on the technical circumstances and the time under and at which the armatures and valves are mounted, adjusted and commissioned, you must take into account particular safety aspects in each case!

If, for example, a pneumatic actuator works a slide in an operational chemical plant, the potential hazards of commissioning have another dimension from that when this is only being carried out for test purposes in a „dry“ part of the plant in the assembly room!

Since we do not know the circumstances at the time of the mounting/adjustment/commissioning, you may find advices on hazards in the following descriptions which are not relevant to you.

Please observe (only) the advices which applies to your situation!

### 3.1 Personal advice

#### 3.1.1 Safety advices for mounting



**We wish to point out expressly that the mounting, adjusting and at accessories the pneumatical and electrical installation of the armatures and valves must be carried out by trained specialist personnel having mechanical, pneumatical and electrical knowledge!**



**Secure that the machine / plant come up to the Machinery Directive after the mounting and installing of the armatures and valves.**



**Switch off all the devices / machines / plant affected by mounting or repair. If appropriate, isolate the devices / machines / plant from the mains.**



**Check (for example in chemical plants) whether the switching off of devices / machines / plant will cause potential danger.**



**If appropriate, in the event of a fault in the armature / valve (in a plant which is in operation) inform the shift forman / safety engineer or the works manager without delay about the fault, in order, for example, to avoid an outflow / overflow of chemicals or the discharge of gases in good time by means of suitable measures!**



**Before mounting or repairing, remove the pressure from pneumatic / hydraulic devices / machines / plant.**



**If necessary, set up warning signs in order to prevent the inadvertent starting up of the devices / machines / plant.**



**Observe the respective relevant professional safety and accident prevention regulations when carrying out the mounting / repair work.**



**Check the correct functioning of the safety equipment (for example the emergency push off buttons/ safety valves, etc)!**

#### 3.1.2 Safety advice for adjustment / starting



**As a result of the starting (pneumatic, electric or by hand) of the armatures and valves the flow of gases, steam, liquids, etc. may be enabled or interrupted!** Satisfy yourself that, as a result of the starting or the test adjustment no potential hazards will be produced for the personnel or the environment!

## Safety advice

---



If necessary, set up warning signs in order to prevent the inadvertent starting up or shutting down of the device / machine / plant!



By ending the adjustment check the correct function and should the occasion arise the position of the slide / valve / flap.



Check the function of the limit switches (option)!



Check, whether the slide / valve / flap will be closed totally, if the control signals the appropriate limit stop!



Through suitable measures, prevent links being trapped by moving actuating elements!



Check the right function of all safety devices (for example emergency push off buttons / safety valves)!



Carry out the starting and the adjustments only in accordance with the instructions described in this documentation!



Adjusting switch on armatures and valves with options (e.g. actuators, solenoid valves, limit switches) there is the risk that live parts (230 V AC~) can be touched!  
Therefore the adjustments must be carried out only by the electrician or a person having adequate training, who is aware of the potential hazard!

### 3.1.3 Safety advice for maintaining / repairing



**Do not carry out any maintenances / repairs if the armature / valve will be under pressure.**

Before disassembling or a armature or valve some essential points should be clarified!

- Will the armature/valve to be disassembled be replaced by another immediately?
- If appropriate, does the production process of the plant needed to be stopped?
- Is it necessary to inform specific personnel about the disassembly?



If necessary, inform the shift foreman/ safety engineer or the manager about the maintenance or repair without delay in order, for example, to avoid an outflow/ overflow of chemicals or a discharge of gases in good time by means of suitable measures!



Observe that some valves / armatures are able to enclose the pressured medium e.g. the ball in the ball valve. You have to relieve the pressure in the pipes in which the armature/valve is mounted.



Switch off pilot pressure and the power supply and relieve the pressure in the pipes.



If necessary set up warning signs in order to prevent

- the inadvertent starting up of the devices/machines/plants in which the armature/valve is mounted
- the switching on of pilot medium supply, pilot power supply and/or the power supply of actuators and accessories.



In case of defect in the armature/valve make contact to the supplier. The telephone number will be found on the back cover of these mounting and installation manual.





If you ascertain a damage of the armature/valve, isolate the device from the mains. Please observe the safety advices.



Do not mount, start or adjust the armature/valve if itself, the pipes or a mounted actuator will be damaged.



After the maintenance or repair check the right function of the armature/valve and the tightness of the pipe connections.



Also check the function of the accessories e.g. actuators, limit switches, etc.

### 3.2 Device safety

The armatures/valves

- are quality products which are produced in accordance to the recognized industrial regulations.
- left the manufacturer`s work in a perfect safety condition.



**In order to maintain this condition, as installer / user you must carry out your task in accordance with the description in these instructions, technically correctly and with the greatest possible precision .**

We assume, as a trained specialist you are having mechanical and electrical knowledge!



**Satisfy yourself that the armatures/valves will only be used within their admissible limiting value (see the technical data) .**



**The armatures/valves must be used only for a purpose corresponding to their construction!**

**The armatures/valves must be used within the values specified in the technical data!**



**The operating of the armature/valve outside the nominal temperature range could destroy the sealings and the bearings.**

**The operating of the armatures/valves outside the nominal pressure range could destroy the inner parts and the body.**



**Never remove a cap or a other component part if the armature/valve will be under pressure.**



Do not mount, start or adjust the armature/valve if itself, the pipes or a mounted actuator will be damaged.



After the maintenance or repair check the right function of the armature/valve and the tightness of the pipe connections.



Also check the function of the accessories e.g. actuators, limit switches, etc.

# Name-plate

## 4 Name-plate

In some cases the armatures/valves will be provided with a name-plate, which permits a definite identification of the armatures/valves and shows the most important technical data to you. The name-plate should not be displaced or changed

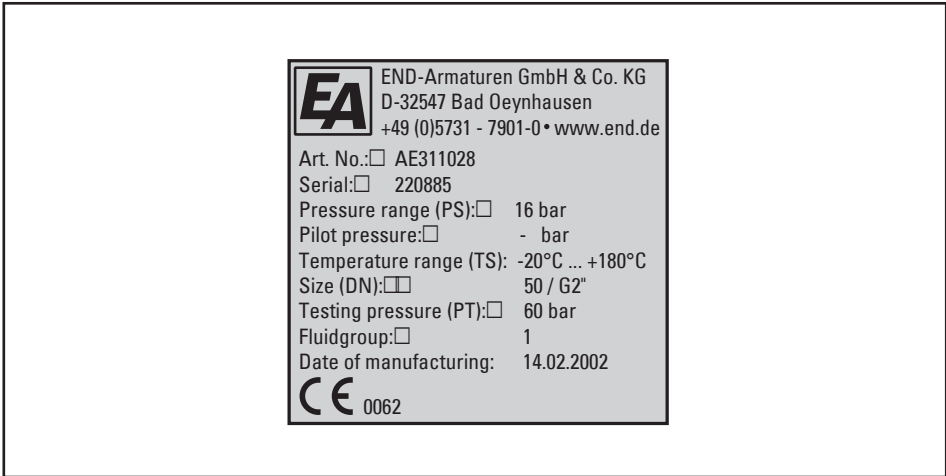

Fig. 4.1 - Name-plate

<b>Art.No.</b>	article number of the valve / armature
<b>Serial</b>	order- or production- number
<b>Pressure range (PS)</b>	max. admissible working pressure of the valve / armature [bar]
<b>Pilot pressure</b>	recommend pilot pressure for correct function of the valve / armature [bar] (only at pneumatic actuated valves / armatures)
<b>Size (DN)</b>	connecting size of the valve / armature
<b>Testing pressure (PT)</b>	testing pressure of the body of the valve / armature
<b>Fluidgroup</b>	allowed fluidgroup of the valve / armature
<b>Date of manufacturing</b>	month and year of manufacturing of the valve / armature

## 5 Ball valves

### 5.1 General

**Before you are mount, adjust, start, operate or disassemble a ball valve you have to read the**



→ **Safety advices**

**If you have not read the safety advices until now, read this important advices now and turn back to this point.**

### 5.2 Corresponding use

Ball valves will be used to cut off medium flow.

It should only be used clean liquids and gases, on which the material of the ball valve will be resistant. Pollution or using outside the nominal pressure range and/or the nominal temperature range should causes damages on the armature especially on the seals.

In some cases you have to install an equalization boring into the ball, that there will be no overpressure between the body and the ball by changing temperatures.

### 5.3 Operation

The ball valve will be open or close totally by using a handle or an pneumatic or electric actuator (option).



**During the operation of the ball valve take care that there won't be insert any objects or limbs into the armature.** Heavy injuries or damages will be the consequence. **If it is necessary you have to install a protective device.**

### 5.4 Mounting / Disassembly

The mechanical installation will be same at all variants of the ball valve. There will be differences in the type of connection.



Observe the flow direction: the handle should point at the flow direction.



Remove the package and the safety devices (e.g. caps or plugs). Take care that there will be no parts of the package or other parts in the armature.







Clean up the pipes in which the ball valve will be mounted. Pollution could affect the safety in operation and the duration of life of the armature. If necessary you have to install a Y- strainer in front of the ball valve.



Avoid stress in case of non align pipes.

# Ball valves

## 5.4.1 Mounting with threaded connection

-  Before lay on sealing compounds, check the hardly screwing by the pipes into the valve body.
-  Lay on the correct sealing compounds on the pipes end. By using PTFE-ribbon or hemp sealings observe the screw direction. Don't use sealing compounds which are not prescribed for your employment.
-  Screw the pipes into the connection ends of the valve. Don't use the handle as a lever.
-  Strike up the pipes with pressure after that time the manufacturer of the sealing compounds pre-tends to harden it.
-  Check the tightness of all connections.

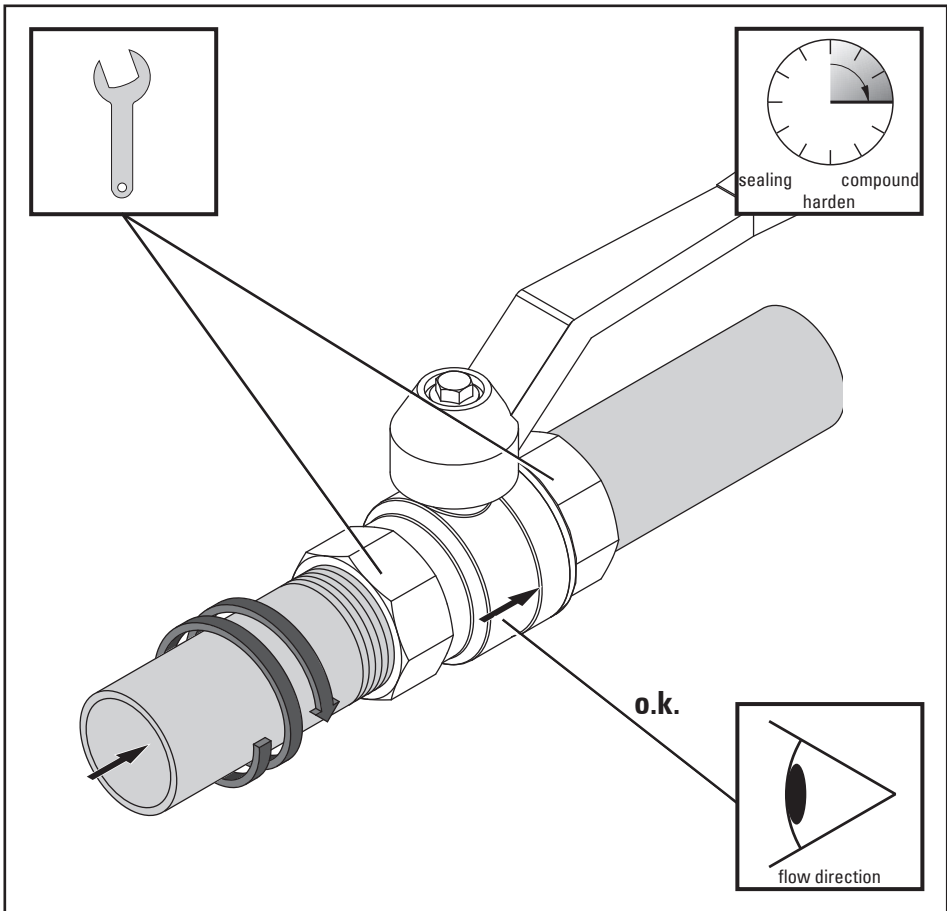

Fig. 5.1 - ball valves, mounting threaded connection (Fig.: Art. TB111025)

## 5.4.2 Mounting with welded connection



**Before welding you have to disassemble the center part of the ball valve to prevent the sealings from damages.**

### 5.4.2.1 Disassembly of the center part of the ball valve



Clamp the valve between a vice carefully. By using guard plates you can prevent the damage of the ends of the body.



Loosen the nuts crossvice and remove the screws out of the body.



Take the center part of the ball valve. Observe, that you didn't drop the sealings or the ball. Put the parts aside carefully. To attach the center parts and the connection ends at a later mounting you can sign the parts.

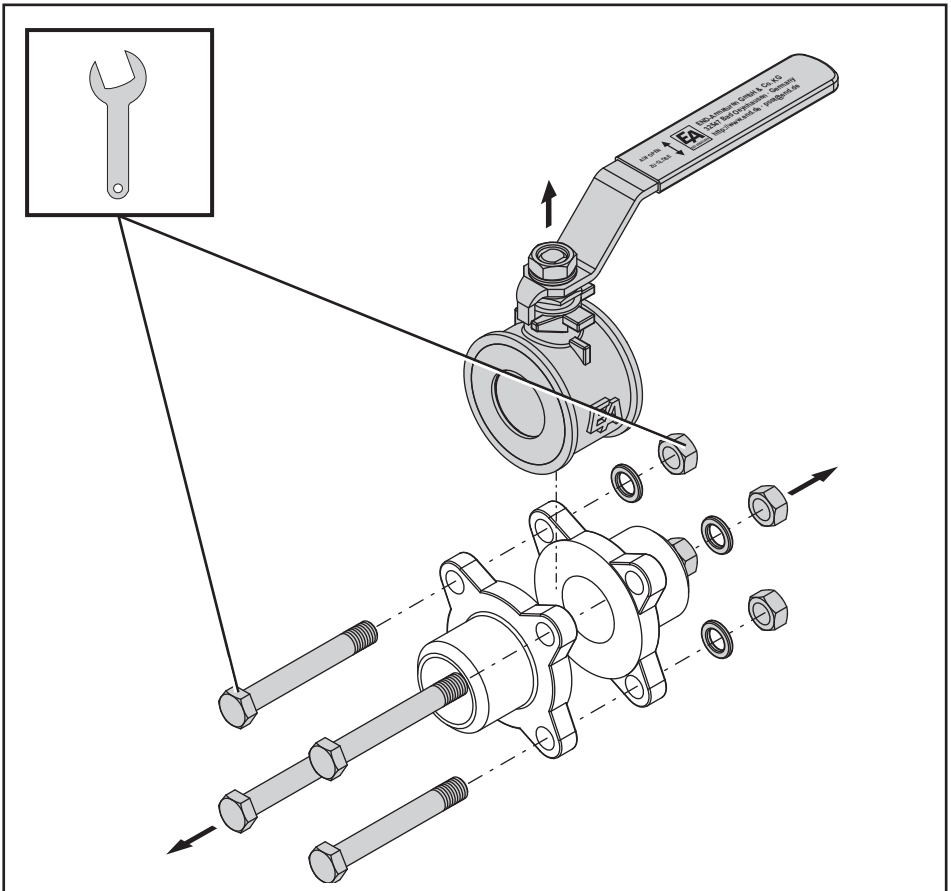

Fig. 5.2 - ball valves, mounting welded connection, disassembly of the center part (Fig.: Art. ZE311064)

## 5.4.2.2 Welding of the connection ends



The center part of the ball valve must substitute by a distance part as long as the center part during the welding.



By welding the valve body with the pipes observe appropriate demands and guide lines.



**The safety demands by welding are depending on the place and the position of the point of weld. Welding the parts at a serviceable device/machine/plant the potential of danger is as higher as welding the parts in a welding room.**



**If appropriate, inform the shift foreman/safety engineer or the works manager and the fire brigade of your factory.**

**By welding observe your own national guide lines about safety and pevention of accidents.**

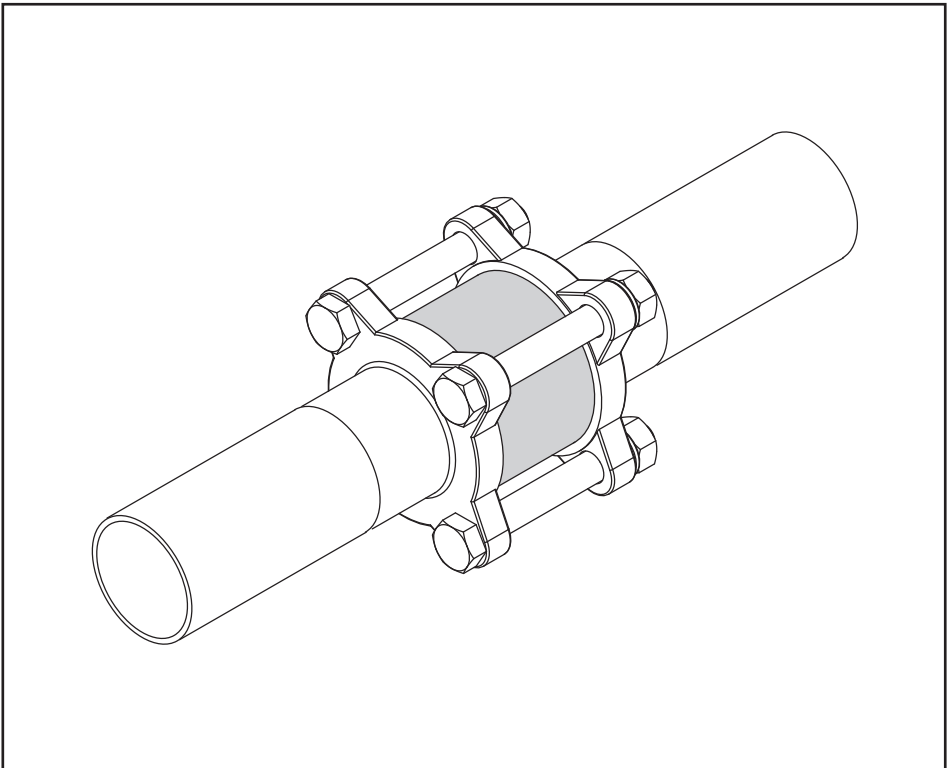

Fig. 5.3 -ball valves,mouting welded connections, welding of the connection ends(Fig.: Art. ZE311064)

## 5.4.2.3 Mounting of the center part



Before mounting the center part let the connection ends cool down.



Disassemble the distance part.



Insert the center part between the connection ends. Attach the center parts to the right connection ends.



Observe the correct seat of the sealings and that there will be no pollution in the seats of the sealings and in the ball.



Insert the screws into the borings of the connection ends. Tighten the nuts equally and crosswise. Observe the max. torque of the screws.



Check the function of the ball valve.



Check the tightness of all connections.

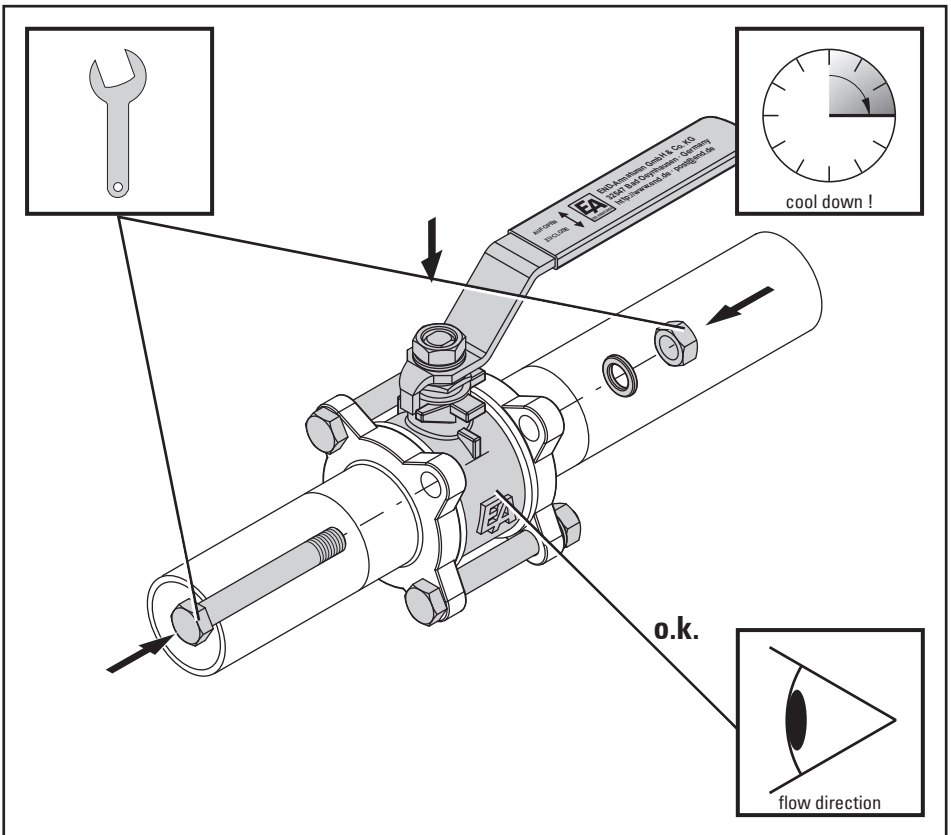

Fig. 5.4 - ball valves, mounting welded connections, mounting of the center part of the ball valve (Fig.: Art. ZE311064)

# Ball valves

## 5.4.3 Mounting with flanged connection



In the following discription we assume that you have mounted the flanges at the end of the pipes and the ball valve (welded flanges) and they are cooled down.



Insert the ball valve and the flange sealings between the flanges.



Align the flange borings und put fit screws through the borings.



Put fit nuts on the screws and tighten them equally and crossvice. Observe the required and the max. torque of the ball valve, the flanges, the flanges seals and the screws.



Check the tightness of all connections.

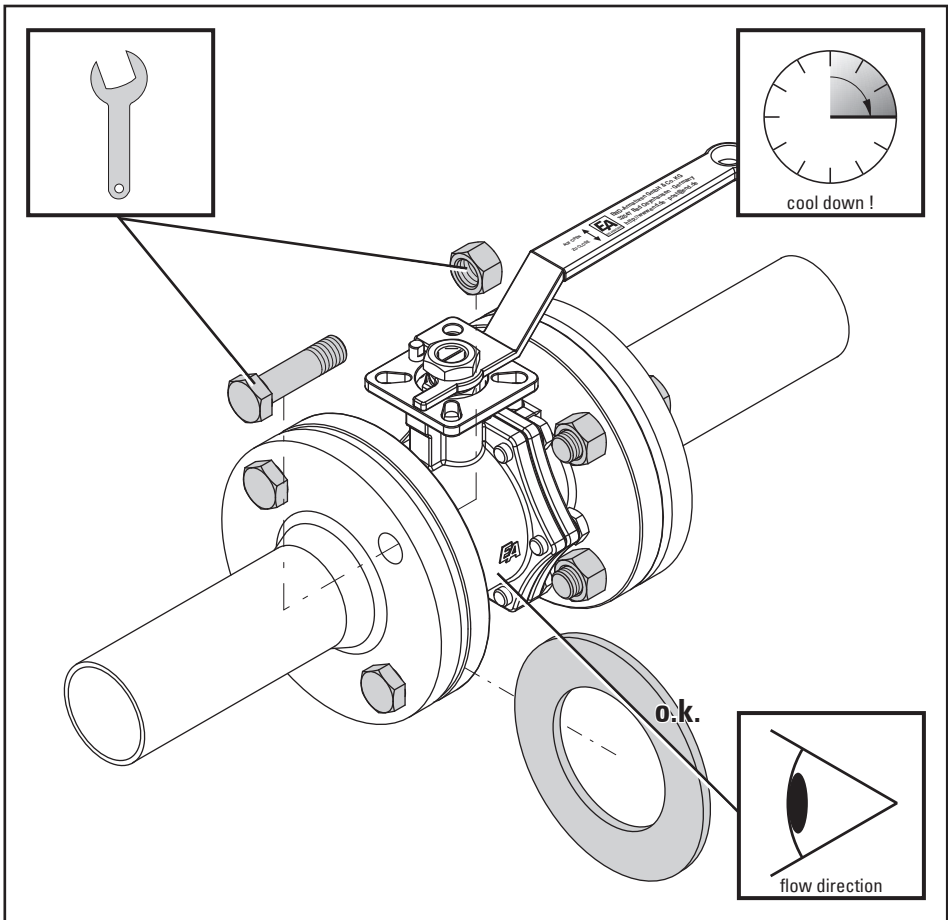

Fig. 5.5 - ball valves, mounting flanged connection (Fig.: Art. ZP311007)



## 5.5 Maintenance

**Before you maintain or shut down the valves you have to read the**



→ **Safety advice**

**If you have not read the safety advices until now, read this important advices now and turn back to this point.**



On normal accounts the ball valve is maintenance free. In periodical turns the controlling of the function and the tightness should happen:

- check the tightness of the gland
- check the tightness of the ball seats



Depending on the version of the ball valve for decreasing tightness at the stem the gland could be readjust. See also chapter 5.5.1. „Readjusting of the gland“.



Ball valves in a multiple part design could be disassemble to exchange the seals and/or the ball. See also chapter: 5.5.2. „Exchange of the ball and the sealings“.







**In case of a defect of the valve make a contact to the supplier. The telephone number will be found on the back or these operation and installation manual.**

**If you ascertain a damage of the valve switch off the device/ machine/ plant! However before doing this, it is essential to refer to the**

→ **Safety advice.**

# Ball valves

## 5.5.1 Readjusting of the gland

-  For decreasing tightness at the stem the gland could be readjust.
-  By keeping the nominal pressure you have to tighten up the screw of the gland until the tightness of the the gland will be restored
-  After the readjusting the ball of the valve must be able to move slightly.
-  At ball valves with spring forced sealings or o-ring sealings at the stem the readjustment isn't necessary.

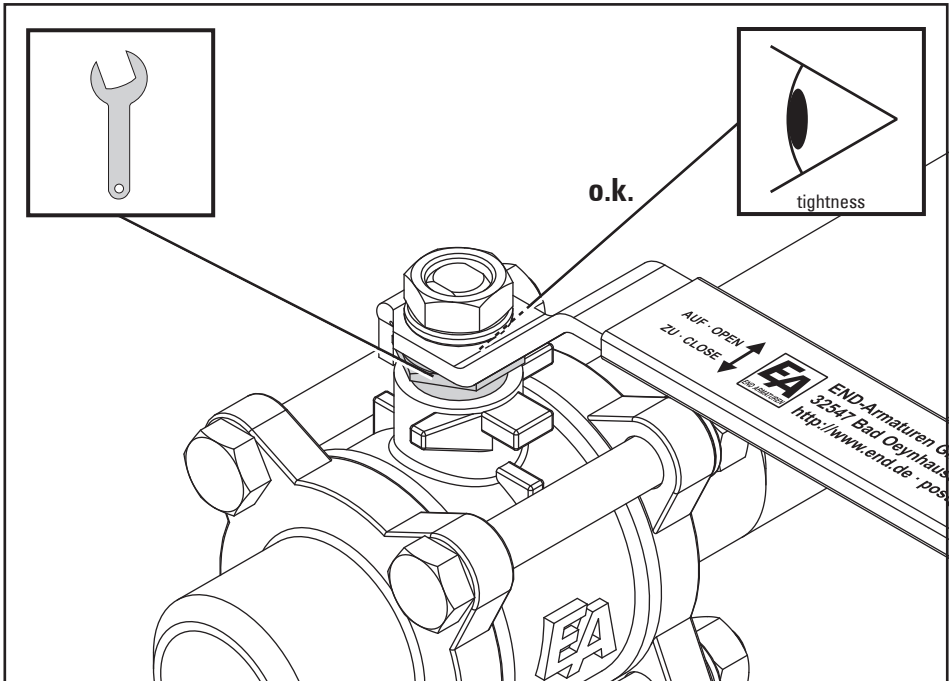

Fig. 5.6 - ball valves, readjusting of the gland (Fig.: Art. ZE311064)

## 5.5.2 Exchange of the ball and the sealing



For decreasing tightness the ball and/or the sealings of the ball valve could be exchange. The availability of the spare parts kit you can see in the data sheet of your ball valve.

Corresponding to the wear of the parts exchange the sealings and the ball. By the replacement of the ball you should also exchange the sealing.



In the following description we assume, that your ball valve will be actuated by hand. If your ball valve will be actuated by a pneumatic or electric actuator, please also observe the operation and installation manual of the actuator.



Cut off the media flow and relieve the media pressure.



Keep ready some fit tanks to catch up leaking liquids.



If it's necessary remove the additional limit switches and gear boxes.

### 5.5.2.1 3-part ball valve with threaded or welded connection



At 3-part ball valve it will do when you remove the center part of the ball valve. Loosen the nuts crosswise and remove the screws out of the body.



Take the center part of the ball valve. Observe, that you didn't drop the sealings or the ball. Put the parts aside carefully.

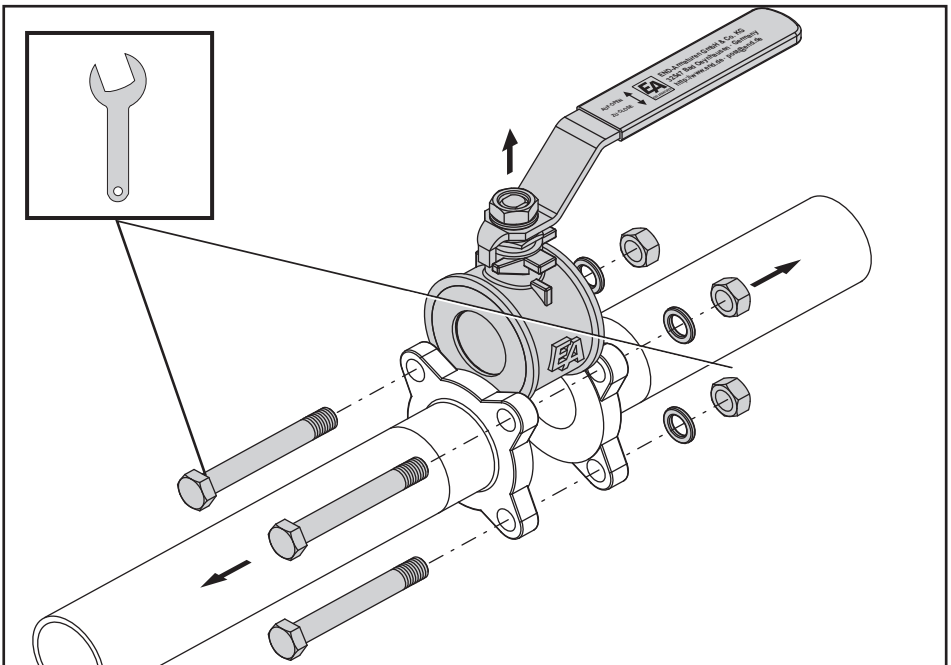

Fig. 5.7 - ball valves, replacement of the sealing kit: removal of the center part (Fig.: Art. ZE311064)

## Ball valves



**Observe that ball valves could enclose medium inside the ball.**



Take the parts aside carefully. Place a mark on the body and the connection ends that you will be able to join the correct parts by a subsequent mounting.



Remove the ball seals and the ball out of the body.



**Perhaps you have to turn the handle to remove the ball out of the body. Do not insert any limbs into the ball valve. Heavy injuries will be the consequences.**



Loosen the nut of the handle and take the handle and all discs and washers aside.



Depending on the version of the ball valve loosen the nut on the stem or loosen the gland nut



Remove the stem and all other sealings, washers and discs out of the body.



Clean all parts and check them for damages.



Throw away the old pieces by observing the appropriate demands and guide lines.

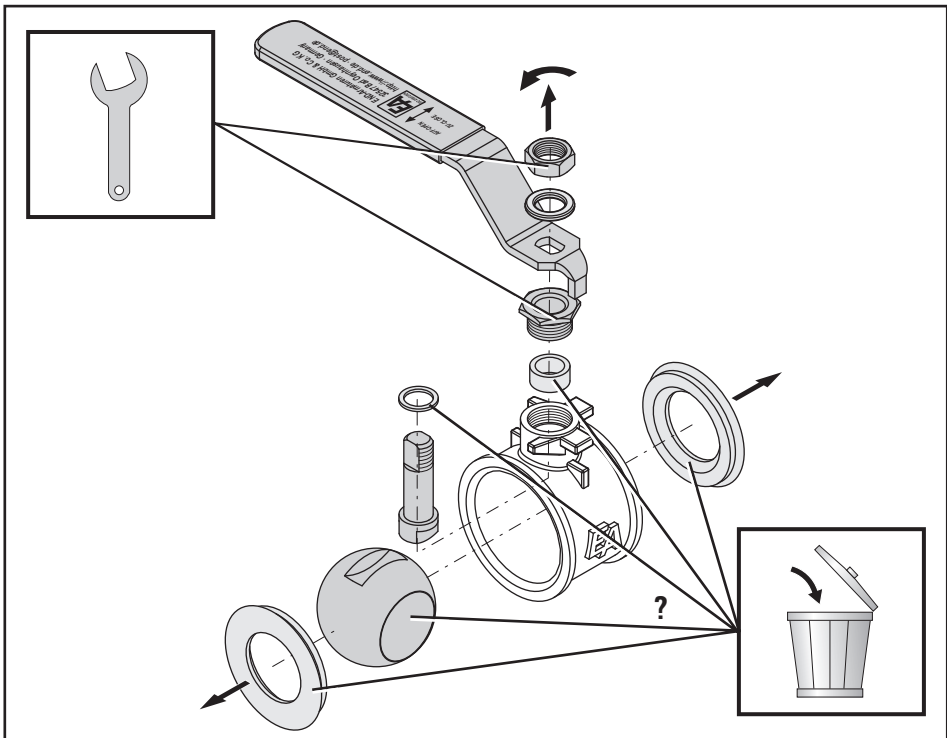













Fig. 5.8 - ball valves, replacement of the sealing kit: removal of the inner parts (Fig.: Art. ZE311064)

-  Make the stem with the new sealings and discs complete.
-  Insert the stem from the inside into the body.
-  Depending on the version of the ball valve mount the other sealings, discs and spring washers at the stem, and screw the nut or the gland nut onto the stem.
-  Insert the ball into the body. The dihedral of the stem must engage in the groove of the ball. If need be you have to turn the stem.
-  Put the handle onto the stem. Observe the correct function of the limit switches and take care that the handle and the boring of the ball will align.
-  Fix the nut of the handle onto the stem and tighten it.
-  Put the ball sealings and the ball into their seats at the center part of the ball valve. Observe, that you didn't drop the sealings or the ball.
-  Before mounting the center part clean the connection ends at the end of the pipes.
-  Move the center part of the body between the connection ends. If need be arrange the center parts to the correct connection ends.
-  Insert the screws into the borings of the connection ends. Tighten the nuts equally and crosswise. Observe the max. torque of the screws.

For mounting read the advices at chapter



→ 5.4.2.3. „Mounting of the center part“.

-  Check the function of the ball valve.
-  Check the tightness of all the connections.

If need be adjust the gland of the stem. Please read the advices at chapter



→ 5.5.1. „Readjusting of the gland“.

# Ball valves

## 5.5.2.2 Multiple part ball valve with flanged connection

 Remove the ball valve out of the pipes. Loosen the flange screws and pull the screws out of the flange.

 Take the ball valve from the pipes.

 Throw away the old pieces by observing the appropriate demands and guide lines.

Dismantle the ball valve. Depending on the version of the ball valve:

-  • you have to screw out the screw of the body, or
- you have to screw the screw joint out of the body.

 Observe, that you didn't drop the sealings or the ball.



**Observe that ball valves could enclose medium inside the ball.**

 Put the parts aside carefully. Place marks on the parts that you will be able to join the correct parts by a subsequent mounting of the ball valve.

 Remove the ball sealing and the ball out of the body.

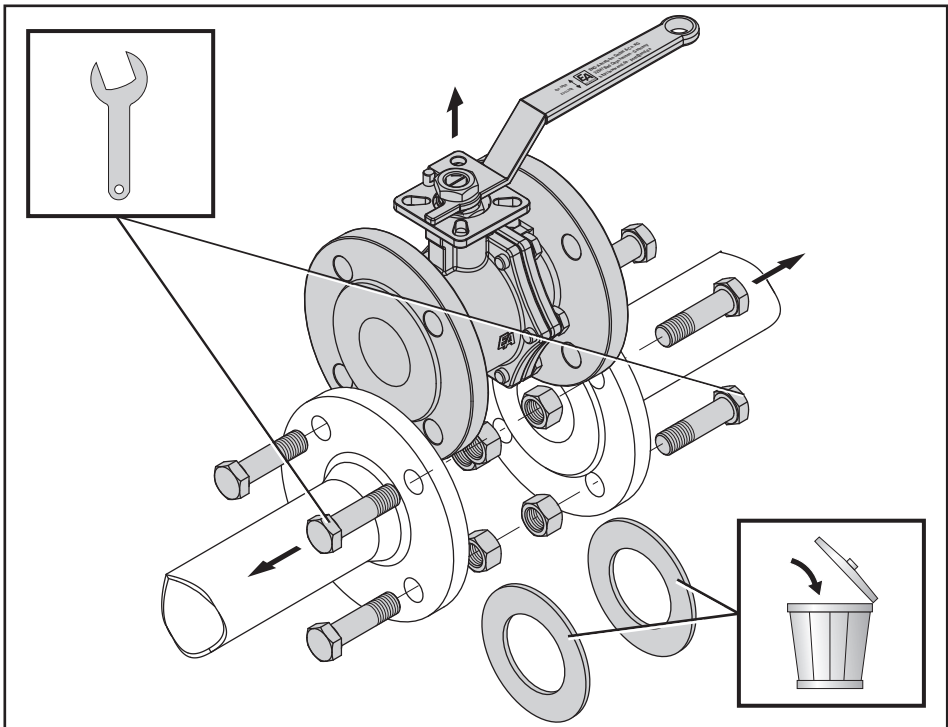

Fig. 5.9 - Ball valves, replacement of the sealing kit: removal of the ball valve (Fig.: Art. ZP311007)



Perhaps you have to turn the handle to remove the ball out of the body. Do not insert any limbs into the ball valve. Heavy injuries will be the consequences..



Remove the second ball sealing.



Loosen the nut of the handle and take the handle and all discs und washers aside.



Depending on the version of the ball valve loosen the nut on the stem or loosen the gland nut



Remove the stem and all other sealings, washers and discs out of the body.



Clean all parts and check them for damages.



Throw away the old pieces by observing the appropriate demands and guide lines.

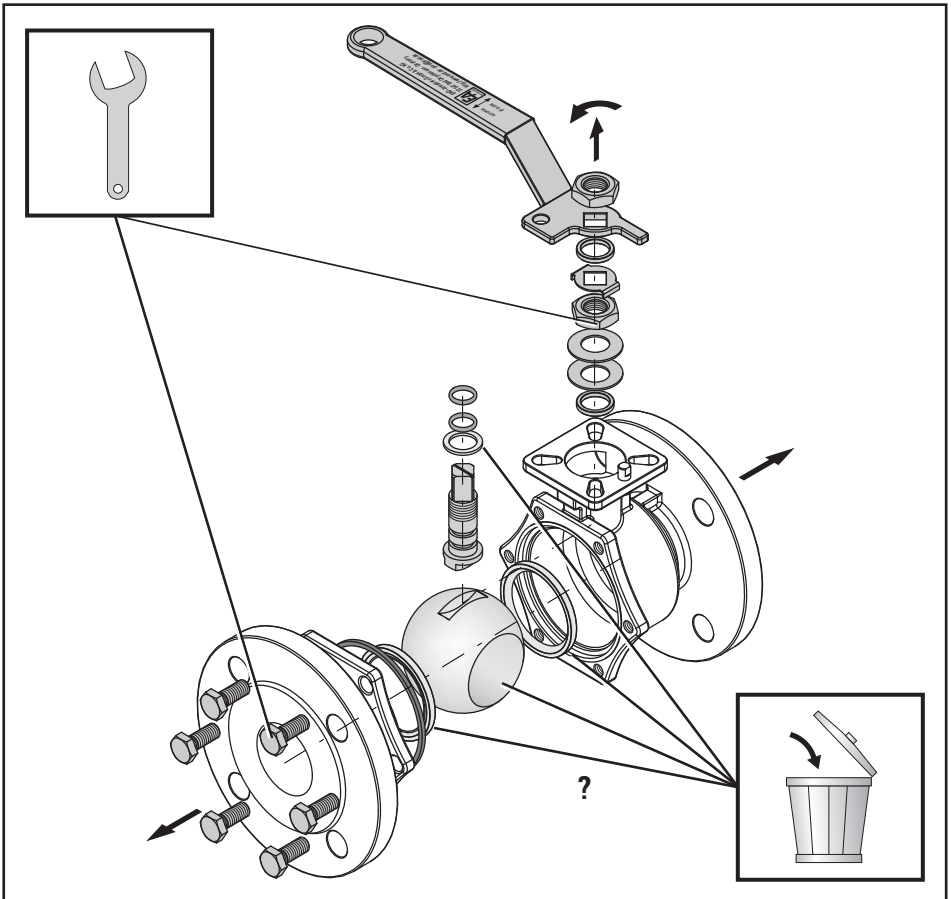

Fig. 5.10 - ball valves, replacement of the sealing kit: removal of the inner parts (Fig.: Art. ZP311007)

## Ball valves

---



Make the stem with the new sealings and discs complete.



Insert the stem from the inside into the body.



Depending on the version of the ball valve mount the other sealings, discs and spring washers at the stem, and screw the nut or the gland nut onto the stem.



Place the first ball seal into the seat in the body.



Insert the ball into the body. The dihedral of the stem must engage in the groove of the ball. If need be you have to turn the stem.



Place the second ball seal into the seat in the body.

Assemble the ball valve. Depending on the version of the ball valve:



- you have to join the parts of the body together and to screw them up with the fit screws; or
- you have to screw up the screw joint with the body.



If need be attach the different parts of the body.



Put the handle onto the stem. Observe the correct function of the limit switches and take care that the handle and the boring of the ball will align.



Fix the nut of the handle onto the stem and tighten it.



Before mounting the center part clean the connection ends at the end of the pipes.



Insert the ball valve with new flange sealings between the flanges.



Align the flange borings und put fit screws through the borings.



Put fit nuts on the screws and tighten them equally and crossvice. Observe the max. torque of the screws.

For mounting read the advices at chapter



→ **5.4.3 „Mounting with flanged connection“.**



Check the function of the ball valve.



Check the tightness of all the connections.

If need be adjust the gland of the stem. Please read the advices at chapter



→ **5.5.1. „Readjusting of the gland“.**









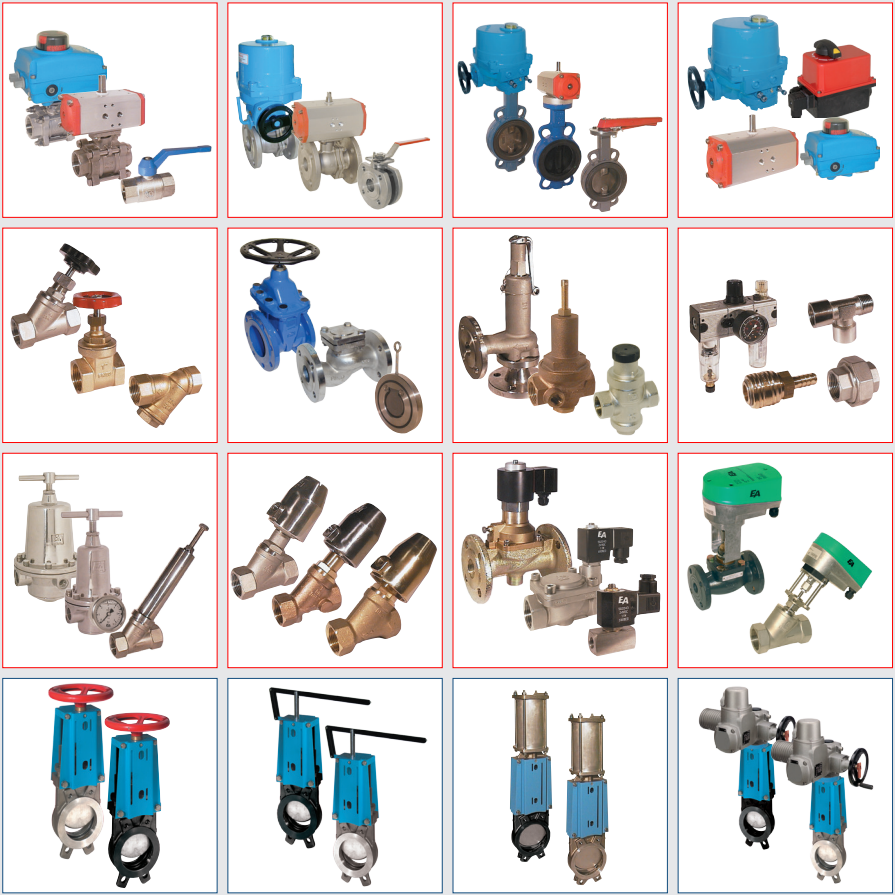

*Qualität von Anfang an.*

**END-Armaturen GmbH & Co. KG**  
 Oberbeckener Str.78  
 D-32547 Bad Oeynhausen  
 Telefon +49 (0) 5731 / 7900-0  
 Telefax +49 (0) 5731 / 7900-199  
 Internet <http://www.end.de>  
 E-Mail [post@end.de](mailto:post@end.de)

**Watergates GmbH & Co. KG**  
 Oberbeckener Str.78  
 D-32547 Bad Oeynhausen  
 Telefon +49 (0) 5731 / 7900-0  
 Telefax +49 (0) 5731 / 7900-199  
 Internet <http://www.watergates.de>  
 E-Mail [post@watergates.de](mailto:post@watergates.de)

ISO 9001

**BUREAU VERITAS**  
 Certification



N° INT0209DE